



RAMBERTI

Migani
ITALIA INDUSTRIE

ALL SUN

RAMFIL

12th LIVING
LA TELONERIA



MADE IN ITALY



INDICE - INDEX

LETTINI E SDRAIO / SUNBEDS AND DECKCHAIRS / TRANSATS ET CHILIENNES / TUMBONAS Y SILLAS

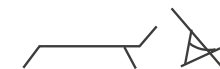

9

CUSCINI E MATERASSINI / CUSHIONS AND MATTRESSES / COUSSINS ET MATELAS / COJINES Y COLCHONES



40

OMBRELLONI / PARASOLS / PARASOLS / SOMBRILLAS



57

DAYBEDS - GAZEBO / DAYBEDS - GAZEBOS / DAYBEDS - PERGOLAS / DAYBEDS Y GAZEBO



84

PEDANE / PLATFORMS / PLATEFORMES / PLATAFORMAS



92

CABINE / BEACH CABINS / CABINES / CABINAS



94

SEDUTE E TAVOLI / SEATS AND TABLE / SIÈGES ET TABLES / ASIENTOS Y MESAS



95

PIANI TAVOLO / TABLE TOPS / PLATEAUX DE TABLE / TABLEROS DE MESA



111

COLLEZIONI / COLLECTIONS / COLLECTIONS / COLECCIONES



115

FINITURE LEGNO / WOOD FINISHES / FINITIONS BOIS / ACABADOS MADERA



127

FINITURE ALLUMINIO / ALUMINIUM FINISHES / FINITIONS ALUMINIUM / ACABADOS ALUMINIO



128

TESSUTI / CANVASES AND FABRICS / TOILES ET TISSUS / TEJIDOS



130

LA TELONERIA

144

Perchè scegliere Ramberti Group

Ampia gamma di prodotti totalmente Made in Italy

I nostri siti produttivi (ad oggi 7) per un totale di oltre **15.000 m²**, si trovano in Italia, più precisamente in Romagna (nella provincia di Rimini e dintorni).

Completiamo tutta la filiera produttiva partendo dal granulo PVC, proseguendo con la tessitura, la lavorazione del legno e dell'alluminio.

Il nostro assortimento totale comprende **oltre 70 articoli diversi**, disponibili in molteplici formati, in varie dimensioni e con oltre **120 varianti di colore** per lettini e sedute, e una scelta di **più di 80 combinazioni di colore** per i tessuti degli ombrelloni, per poter offrire alla nostra clientela oltre **22.000 possibilità di scelta** tra lettini, ombrelloni, sedute, tavoli e gazebo, tutto rigorosamente **Made in Italy**.

Prodotti pregiati e assistenza garantita

Perseguiamo consapevolmente una strategia di **assistenza tempestiva al Cliente**, pre e post vendita, anche tramite i **Ramberti Points** presenti sul territorio italiano ed estero.

Prodotti professionali realizzati per durare negli anni

I nostri prodotti sono studiati e realizzati per **durare molti anni**. Gli articoli in alluminio persino **dopo decenni** sono riparabili e rivestibili nuovamente.

Sostenibilità

I prodotti in legno sono in **frassino della migliore qualità**, proveniente da foreste austriache e **certificato PEFC** www.pefc.it e **FSC** <https://it.fsc.org/it-it>. selezionato ed accuratamente lavorato in spessori tali da garantire al prodotto la **massima resistenza**.

Oltre 106 anni di esperienza

La passione, la curiosità, lo spirito d'innovazione e **oltre 106 anni di esperienza artigianale** ci motivano giorno dopo giorno come **produttore leader per questa tipologia di arredi per outdoor**.

Why choose Ramberti group

Wide range of products completely Made in Italy

Our production sites (currently 7) cover an area of **over 15,000 m²** and are all in Italy's Romagna region, specifically in the province of Rimini and its surrounding areas.

We manage the entirety of our production chain, starting from the PVC granules, and continuing with the weaving, the woodworking and the aluminium processing. Our total assortment includes **over 70 different items**, available in different shapes and sizes, and with **over 120 color variations** for sunbeds and seats, and a choice of **more than 80 color combinations** for the parasol fabrics, to offer to our customers **over 22,000 choices** between sunbeds, parasols, seats, tables and gazebos, all strictly **Made in Italy**.

High-quality products and guaranteed assistance

We consciously grant a strategy of **timely customer service**, before and after sales, also through our **Ramberti Points**, located both in Italy and abroad.

Professional products made to last for years.

Our products are designed and manufactured **to last many years**. Aluminum items can be repaired and relined **even after decades**.

Sustainability

Our wooden products are made of the **highest quality of ashwood**, coming from Austrian forests and **certified PEFC** www.pefc.it and **FSC** <https://it.fsc.org/it-it>. Selected and accurately worked in thicknesses such as to guarantee the product **maximum resistance**.

Over 106 years of experience

Passion, curiosity, our spirit of innovation, and **more than 106 years of artisanal experience** motivate us day after day as the **leading manufacturer of this type of outdoor furniture**.

Pourquoi choisir le Groupe Ramberti

Large gamme de produits totalement Made in Italy

Nos sites de production (actuellement 7) couvrent une superficie de **plus de 15.000 m²** et sont tous situés dans la région italienne de la Romagne, plus précisément dans la province de Rimini et ses environs.

Nous gérons l'intégralité de notre chaîne de production, à partir des granulés de PVC, en continuant avec le tissage, le travail du bois et le traitement de l'aluminium.

Notre assortiment total comprend **plus de 70 articles différents**, disponibles en différentes formes et dimensions, et avec **plus de 120 variations de couleurs** pour les transats et les sièges, et un choix de **plus de 80 combinaisons de couleurs** pour les tissus des parasols, pour offrir à nos clients **plus de 22.000 choix** entre transats, parasols, sièges, tables, et gazebos, tous strictement **Made in Italy**.

Produits de haute qualité et assistance garantie

Nous garantissons consciemment une stratégie de **service client ponctuel**, avant et après vente, également à travers nos **Ramberti Points** situés en Italie et à l'étranger.

Produits professionnels conçus pour durer des années

Nos produits sont conçus et fabriqués pour **durer de nombreuses années**. Les articles en aluminium peuvent être réparés et regarnis même **après des décennies**.

Durabilité

Nos produits en bois sont fabriqués à partir de **la plus haute qualité de frêne**, provenant des forêts Autrichiennes et **certifiés PEFC** www.pefc.it et **FSC** <https://it.fsc.org/it-it>. Sélectionnés et travaillés soigneusement dans des épaisseurs telles qu'ils garantissent au produit une **résistance maximale**.

Plus de 106 ans d'expérience

La passion, la curiosité, notre esprit d'innovation et **plus de 106 ans d'expérience artisanale** nous motivent chaque jour en tant que **fabricant leader de ce type de mobilier d'extérieur**.

Por qué elegir Ramberti Group

Amplia gama de productos totalmente Made in Italy

Nuestros centros de producción (hasta la fecha 7) con un total de más de **15.000 m²**, se encuentran en Italia, más precisamente en Romaña (en la provincia de Rimini y sus alrededores).

Completamos toda la cadena de producción partiendo del grano PVC, continuando con el tejido, la elaboración de la madera y del aluminio.

Nuestro surtido total incluye **más de 70 artículos diferentes**, disponibles en múltiples formatos, en varios tamaños y con **más de 120 variantes de color** para tumbonas y asientos, y una selección de más de 80 combinaciones de colores para los tejidos de las sombrillas, para poder ofrecer a nuestra clientela **más de 22.000 posibilidades de elección** entre tumbonas, sombrillas, asientos, mesas y gazebo, todo estrictamente **Made in Italy**.

Productos de alta calidad y servicio garantizado

Perseguimos conscientemente una estrategia de **asistencia oportuna al Cliente**, pre y post venta, también a través de los **Ramberti Points** presentes en el territorio italiano y extranjero.

Productos profesionales fabricados para durar años

Nuestros productos están diseñados y fabricados para **durar muchos años**. Incluso después de décadas, los artículos de aluminio se pueden **reparar y volver a revestir**.

Sostenibilidad

Los productos de madera son de **fresno de la mejor calidad**, procedente de bosques austriacos y **certificado PEFC** www.pefc.it y **FSC** <https://it.fsc.org/it-it>. Seleccionado y cuidadosamente trabajado en espesores que garantizan al producto la **máxima resistencia**.

Más de 106 años de experiencia

La pasión, la curiosidad, el espíritu de innovación y **más de 106 años de experiencia artesanal** nos motivan día a día como **productor líder para este tipo de mobiliario para exteriores**.

RAMBERTI

Migani
ITALIA INDUSTRIE

ALL SUN

RAMFIL

12thLIVING

LA TELONERIA

it /

La produzione degli articoli avviene totalmente negli stabilimenti produttivi del gruppo.

Le diverse realtà industriali, **direttamente controllate e facenti capo al Gruppo Ramberti**, consentono una **attenta verifica delle materie prime impiegate** e della **qualità** dei prodotti:

- dal filato al tessuto;
- dalle strutture in alluminio alle stecche degli ombrelloni;
- dagli articoli in legno ai complementi d'arredo.

Ogni azienda è specializzata nella produzione specificata al fine di valorizzare l'esperienza artigianale della manodopera, permettendo una attenzione sartoriale ai dettagli.

fr /

La fabrication des articles a lieu entièrement dans les usines de production du groupe.

Les différentes réalités industrielles, **contrôlées directement et appartenant au Groupe Ramberti**, permettent une **vérification minutieuse des matières premières utilisées** et de la **qualité** des produits :

- du fil au tissu;
- des structures en aluminium aux baleines des parasols ;
- des articles en bois aux accessoires d'ameublement.

Chaque entreprise se spécialise dans une production spécifique afin d'améliorer l'expérience artisanale de la main-d'œuvre, ce qui permet une attention personnalisée aux détails.

en /

The production of the items takes place entirely in the production plants of the group.

The various industrial realities, **directly controlled and headed by the Ramberti Group**, allow a **careful verification of the raw materials used**, and the **quality** of the products:

- from yarn to fabric;
- from the aluminum structures to the ribs of parasols,
- from wooden items to furnishing accessories.

Each company specializes in the specified production in order to enhance the craftsmanship experience of the workforce, allowing a tailored attention to detail.

es /

La producción de los artículos se realiza íntegramente en las instalaciones de producción del grupo.

Las distintas empresas industriales, **controladas directamente por el Grupo Ramberti y pertenecientes al mismo**, permiten **verificar cuidadosamente las materias primas utilizadas** y la **calidad** de los productos:

- del hilo a la tela;
- desde estructuras de aluminio hasta varillas para sombrillas;
- desde artículos de madera hasta accesorios de decoración.

Cada empresa se especializa en la producción especificada para potenciar el trabajo artesanal de la mano de obra, lo que permite prestar atención a los detalles a medida.





RAMBERTI

it / Azienda di produzione. Montaggio e confezionamento dei semilavorati provenienti dalle altre aziende del gruppo.
 en / Production Company, for the assembly and the packaging of semi-finished products from other companies in the Group.
 fr / Entreprise de production, assemblage et conditionnement, de produits semi-finis provenant d'autres sociétés du Groupe.
 es / Empresa de producción. Montaje y envasado de productos semiacabados de otras empresas del grupo.



Migani

it / Azienda di produzione per la lavorazione del legno e dell'alluminio.
 en / Production Company for the processing of wood and aluminum.
 fr / Entreprise de production pour la transformation du bois et de l'aluminium.
 es / Empresa de producción para la elaboración de madera y aluminio.



ALL SUN

it / Azienda di produzione per la lavorazione dell'alluminio, con speciali macchine dedicate piegatubi e centri di lavoro.
 en / Production Company for the processing of aluminum with special dedicated tube bending machines and work centers.
 fr / Entreprise de production pour le traitement de l'aluminium, avec des cintruses de tubes et des centres d'usinage spéciaux dédiés.
 es / Empresa de producción para la transformación del aluminio, con máquinas curvadoras y centros de mecanizado especiales.



RAMFIL

it / Azienda di produzione del filato e tessitura.
 en / Production Company for yarn and weaving.
 fr / Entreprise de production et de tissage de fil et de tissu.
 es / Empresa de producción del tejido de hilos.



12thLIVING

it / Azienda di produzione per le strutture degli ombrelloni.
 en / Production Company for parasol structures.
 fr / Société de production de structures des parasols.
 es / Empresa de producción de estructuras de paraguas.



LA TELONERIA

it / Teloni in pvc su misura.
 en / Tailor-made PVC covers.
 fr / Couvertures en PVC sur mesure.
 es / Lonas de pvc a medida.

Una storia di famiglia Une histoire de famille A family history Una historia familiar



1918
 it / **Francesco Ramberti** inaugura l'attività imprenditoriale della famiglia come artigiano di selle per cavalli, comprando la prima macchina per cucire.
 en / **Francesco Ramberti** inaugurates the business activity of the family as a craftsman of horse saddles, buying the first sewing machine.
 fr / **Francesco Ramberti** inaugure l'entreprise familiale en tant qu'artisan de selles de chevaux, en achetant la première machine à coudre.
 es / **Francesco Ramberti** inicia el negocio familiar como fabricante de sillas de montar, comprando la primera máquina de coser.

1945

1957

1980

1992

1995

it / Con lo sviluppo delle automobili, l'azienda inizia la produzione di teloni per camion.
 en / With the development of automobiles, the company began the production of tarpaulins for trucks.
 fr / Avec le développement des voitures, l'entreprise commence la production de bâches pour camions.
 es / Con el desarrollo de los automóviles, la empresa inició la producción de lonas para camiones.

it / Con l'esplosione del turismo sulla riviera romagnola, inizia la produzione di lettini e ombrelloni. **Antonio e Roberto**, figli di Francesco, fanno il loro ingresso in azienda.
 en / With the explosion of tourism on the Romagna riviera, the production of sunbeds and parasols begins. **Antonio and Roberto**, Francesco's son, join the company.
 fr / Avec l'explosion du tourisme sur la Riviera Romagnola, la production de transats et de parasols commence. **Antonio et Roberto**, fils de Francesco, rejoint l'entreprise.
 es / Con la explosión del turismo en la costa romañola, comenzó la producción de tumbonas y sombrillas. El hijo de Francesco, **Antonio y Roberto**, se incorporan a la empresa.

it / **Riccardo**, figlio di Antonio, fa il suo ingresso in azienda. Entrambi sono ancora al timone del gruppo.
 en / **Riccardo**, Antonio's son, joins the company. Both are still at the helm of the Group.
 fr / **Riccardo**, le fils d'Antonio, entre dans l'entreprise. Tous deux sont toujours aux commandes du groupe.
 es / **Riccardo**, el hijo de Antonio, se incorpora a la empresa. Ambos siguen al frente del grupo.

it / Apre il primo **Ramberti Point** ad Albenga in Liguria.
 en / The first **Ramberti Point** opens in **Albenga**, Liguria.
 fr / Le premier **Ramberti Point** ouvre à **Albenga** en Ligurie.
 es / Se abre el primer **Punto Ramberti** en **Albenga**, Liguria.

it / **Antonio, Riccardo e Giovanni** liquidano la quota di Roberto.
 en / **Antonio, Riccardo and Giovanni** liquidate Roberto's share.
 fr / **Antonio, Riccardo et Giovanni** liquident la part de Roberto.
 es / **Antonio, Riccardo y Giovanni** liquidan la parte de Roberto.

2001

2012

2014

2017

2019

it / Viene inaugurata **All Sun Srl** per la lavorazione dell'alluminio.
 en / **All Sun Srl** is inaugurated for the processing of aluminium.
 fr / **All Sun Srl** a été inaugurée pour le traitement de l'aluminium.
 es / Se inaugura **All Sun Srl** para la elaboración del aluminio.

it / **Migani Industrie Srl** viene acquisita per la lavorazione del legno e dell'alluminio.
 en / **Migani Industrie Srl** is acquired for the processing of wood and aluminum.
 fr / **Migani Industrie Srl** a été acquise pour le traitement du bois et de l'aluminium.
 es / Se adquiere **Migani Industrie Srl** para la elaboración de la madera y el aluminio.

it / Viene inaugurata **Ramfil Srl** per la produzione del filo e del tessuto.
 en / **Ramfil Srl** is inaugurated for the production of yarn and fabric.
 fr / **Ramfil Srl** a été inaugurée pour la production et de tissage de fil et de tissu.
 es / Se inaugura **Ramfil Srl** para la producción de hilos y tejidos.

it / Entra in azienda il primo figlio di Riccardo: **Luca**. Viene inaugurata **12 Living Srl** per la produzione dei componenti per gli ombrelloni.
 en / Riccardo's first son joins the company: **Luca**. **12th Living Srl** is inaugurated for the production of parasol structures.
 fr / Le premier fils de Riccardo entre dans l'entreprise : **Luca**. **12 Living Srl** a été inaugurée pour la production de structures des parasols.
 es / El primer hijo de Riccardo se incorpora a la empresa: **Luca**. Se inaugura **12 Living Srl** para la producción de componentes de sombrillas.

it / Inaugura il **Ramberti beach 182** in Brasile.
 en / **Ramberti beach 182** is inaugurated in Brazil.
 fr / **Ramberti beach 182** a été inaugurée au Brésil.
 es / Se inaugura **Ramberti beach 182** en Brasil.

2020

it / Apre il terzo **Ramberti Point** a **Cisterna di Latina** nel Lazio.

en / The third **Ramberti Point** opens in **Cisterna di Latina**, Lazio.

fr / Le troisième **Ramberti Point** ouvre à **Cisterna di Latina** dans le Latium.

es / El tercer **Punto Ramberti** se abre en **Cisterna di Latina**, en el Lacio.

2021

it / Viene inaugurato **Ramberti Cuba**.

en / **Ramberti Cuba** is inaugurated.

fr / **Ramberti Cuba** a été inauguré.

es / Se inaugura **Ramberti Cuba**.

2022

it / Entra in azienda la seconda figlia di Riccardo: **Elisa**.

en / Riccardo's daughter joins the company: **Elisa**.

fr / La fille de Riccardo, **Elisa** entre dans l'entreprise.

es / La segunda hija de Riccardo, **Elisa**, se incorpora a la empresa.

2023

it / Entra in azienda il terzo figlio di Riccardo: **Daniele**.

en / Riccardo's son joins the company: **Daniele**.

fr / Le troisième fils de Riccardo entre dans l'entreprise : **Daniele**.

es / Entra en la empresa el tercer hijo de Ricardo: **Daniele**.

2024

it / Riapre La Teloneria. Viene inaugurato **Ramberti Albania**.

en / The Teloneria reopens. **Ramberti Albania** is inaugurated.

fr / Rouvre La Teloneria. **Ramberti Albanie** a été inauguré.

es / Reabre La Teloneria. Se inaugura **Ramberti Albania**.

oggi / today / aujourd'hui / hoy

15.000

m² di stabilimenti produttivi
m² of production plants
m² d'usines de production
m² de fábricas

106

anni di storia e 3 generazioni in azienda
years of history and 3 generations in the company
ans d'histoire et 3 générations l'entreprise
años de historia y 3 generaciones en la empresa

50.000

articoli prodotti ogni anno
items produced every year
articles produits chaque année
artículos producidos cada año

200

km tessuti confezionati ogni anno
km of fabrics manufactured every year
km tissus fabriqués chaque année
km de tejidos confeccionados cada año





Lettini e Sdraio
Sunbeds and Deckchairs
Transats et Chiliennes
Tumbonas y Silla de playa



 misure/ sizes

 L 200 cm
P 79 cm
H 40 cm

 impilabile
stackable
empilable
apilable

 L 200 cm
P 100 cm
H 50 cm
Kg 35
1 pz

 L 200 cm
P 100 cm
H 170 cm
Kg 180
10 pz



CON RUOTE / WITH WHEELS
AVEC ROULETTES / CON RUEDAS

**OPZIONI / OPTIONS /
OPTIONNEL / OPTIONNES:**

Cuscino/Cushion/Coussin/Cojin
50x25 cm, h 3 cm



PORTOFINO

- it / Lettino adatto per piscine e aree relax. 5 diverse posizioni dello schienale con meccanismo a cremagliera, per un maggiore comfort. Partendo dalla posizione stesa è possibile scegliere le altre quattro alzando semplicemente lo schienale. Telaio in alluminio verniciato. Tessuto in pvc. Dotato di un comodo portatelo nella parte sottospalliera. Regolazione dello schienale senza cordella. Le ruote, inserite nel telaio, consentono la movimentazione del lettino. Impilabile. Ferramenta inox AISI 316.
- en / Sunbed suitable for swimming pools and relaxation areas. The ropeless rack mechanism allows to adjust 5 different backrest positions for maximum comfort. Starting from the horizontal position, it is possible to choose the other four by simply raising the backrest. Frame in powder coated aluminum. pvc canvas. The wheels inserted into the frame allow for easy movement of the bed. Stackable. Hardware Inox AISI 316
- fr / Transat idéal pour les piscines et les espaces de détente. 5 positions différentes du dossier avec mécanisme à crémaillère pour un maximum de confort. A partir de la position allongée, il est possible de choisir les quatre autres en relevant simplement le dossier. Structure en aluminium peint avec des poudres époxy. Équipé d'un porte-serviette confortable sur le dessous. Réglage du dossier sans cordon. Toile en pvc. Les roulettes, insérées dans la structure, permettent le mouvement du transat. Empilable. Quincaillerie en acier inoxydable AISI 316.
- es / Tumbona adecuada para piscinas y zonas de relax. 5 posiciones diferentes de respaldo con un mecanismo de cremallera para mayor comodidad. Partiendo de la posición tumbada, es posible elegir las otras cuatro simplemente levantando el respaldo. Estructura de aluminio pintado. Equipada con un cómodo soporte en la parte inferior. Ajuste del respaldo sin cuerda. Tejido de pvc. Las ruedas integradas en la estructura permiten desplazar la tumbona. Apilable. Herrajes de acero inoxidable AISI 316.



p. 128

Finiture in alluminio
 Aluminium finishes
 Finitions en aluminium
 Acabados de aluminio

p. 135-136-138

Tessuti COR e RAM
 COR and RAM canvases
 Toiles COR et RAM
 Tejidos COR y RAM



CARTER SALVADITA
 MECCANISMO
 A CREMAGLIERA

CARTER SAVE FINGERS
 ROPELESS RACK
 MECHANISM

CARTER DE SÉCURITÉ
 MÉCANISME À CRÉ-
 MAILLÈRE

PROTECCIÓN DE DEDOS
 MECANISMO
 DE CREMALLERA



5 POSIZIONI
 5 POSITIONS

5

 misure/ sizes

 L 206 cm
P 64 cm
H 40 cm

 impilabile
stackable
empilable
apilable
max 15
pz/pcs

 L 190 cm
P 65 cm
H 50 cm
Kg 9,5
1 pz

 L 200 cm
P 80 cm
H 180 cm
Kg 110
10 pz

OPZIONI / OPTIONS / OPTIONNEL / OPTIONES:

Parasole/Sunshield/Pare-soleil/Parasol

Ruote/Wheels/Roulettes/Ruedas



max 15 pz/pcs



SANTORINI

it / Lettino adatto per piscine e aree relax. Dotato di 4 inclinazioni dello schienale con scaletta. Telaio in alluminio. Impilabile. Tessuto in pvc. Ferramenta inox AISI 316.

en / Sunbed suitable for swimming pools and relaxation areas. Equipped with 4 ropeless backrest inclinations by ladder. Frame in aluminium. pvc canvas. Stackable. Hardware Inox AISI 316.

fr / Transat idéal pour les piscines et les espaces de détente. Équipé de 4 inclinaisons de dossier avec échelle. Structure en aluminium. Toile en pvc. Empilable. Quincaillerie en acier inoxydable AISI 316.

es / Tumbona adecuada para piscinas y zonas de relax. Equipada con 4 inclinaciones de respaldo con niveles. Estructura de aluminio. Tejido de pvc. Apilable. Herrajes de acero inoxidable AISI 316.



p. 128

Finiture in alluminio
 Aluminium finishes
 Finitions en aluminium
 Acabados de aluminio

p. 135-136-138

Tessuti COR e RAM
 COR and RAM canvases
 Toiles COR et RAM
 Tejidos COR y RAM



4 POSIZIONI
 4 POSITIONS



 misure/ sizes



L 210 cm
P 70 cm
H 45 cm



1 pz

L 210 cm
P 70 cm
H 5 cm
Kg 9 Kg



10 pz

L 210 cm
P 80 cm
H 65 cm
Kg

+



10 pz

L 210 cm
P 200 cm
H 210 cm
Kg



NOIR

p. 128

Finiture in alluminio
Aluminium finishes
Finitions en aluminium
Acabados de aluminio

p. 139

Tessuti MILANO per materassino
MILANO canvases for mattress
Toiles MILANO pour matelas
Tejidos MILANO para colchoneta

it / Lettino adatto per piscine e aree relax. Telaio in alluminio verniciato. Materassino h 40 cm.
Dotato di 4 inclinazioni dello schienale con scaletta. Ferramenta inox AISI 316.

en / Sunbed suitable for swimming pools and relaxation areas. Frame in powder coated aluminium. Mattress h. 40 c.
Equipped with 4 ropeless backrest inclinations by ladder. Hardware Inox AISI 316.

fr / Transat idéal pour les piscines et les espaces de détente. Structure en aluminium peint avec des poudres époxy.
Matelas h. 40 cm. Équipé de 4 inclinaisons de dossier avec échelle. Quincaillerie en acier inoxydable AISI 316.

es / Tumbona adecuada para piscinas y zonas de relax. Estructura de aluminio pintado. Colchoneta h. 40 cm.
Equipada con 4 inclinaciones de respaldo con niveles. Herrajes de acero inoxidable AISI 316.



4 POSIZIONI
4 POSITIONS
4

 misure/ sizes

 L 200 cm
P 100 cm
Hs 22-47 cm

 L 200 cm
P 100 cm
H 8 cm
Kg 36,3
1 pz

 L 200 cm
P 100 cm
H 140 cm
Kg 230
15 pz

+

 L 120 cm
P 80 cm
H 90 cm
Kg 160
60 pz

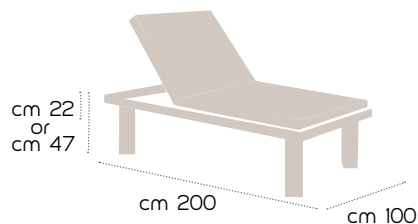

BIG

it / Lettino con telaio in alluminio verniciato. Tessuto in pvc. 4 diverse posizioni dello schienale con meccanismo a cremagliera. Partendo dalla posizione stesa è possibile scegliere le altre alzando semplicemente lo schienale. Con materassino filtrante h.10 cm con tessuto Milano h 10 cm. Disponibile con altezza seduta h. 22 cm o 47 cm. Ferramenta inox AISI 316.

en / Sunbed with powder coated aluminum frame. pvc canvas. The ropeless rack mechanism allows to adjust 4 different backrest positions. Starting from the horizontal position, it is possible to choose the other four by simply raising the backrest. Available with seat height h. 22 cm or 47 cm, and with filtering mattress with Milano canvas h 10 cm. Hardware Inox AISI 316.

fr / Transat avec structure en aluminium peint avec des poudres époxy. Toile en pvc. 4 positions du dossier différentes avec mécanisme à crémaillère. A partir de la position allongée, il est possible de choisir les autres en relevant simplement le dossier. Avec matelas filtrant en toile h.10 cm. Disponible avec une hauteur d'assise h. 22 cm ou 47 cm. Quincaillerie en acier inoxydable AISI 316.

es / Tumbona con estructura de aluminio pintado. Tejido de pvc. 4 posiciones diferentes de respaldo con mecanismo de cremallera. Partiendo de la posición tumbada, se pueden elegir otras simplemente levantando el respaldo. Con colchón filtrante h.10 cm con tejido Milano h 10 cm. Disponible con altura de asiento de 22 cm o 47 cm. Herrajes de acero inoxidable AISI 316.

p. 128

Finiture in alluminio
Aluminium finishes
Finitions en aluminium
Acabados de aluminio

p. 135-136-138-139

Tessuti COR, RAM e MILANO
COR, RAM and MILANO canvases
Toiles COR, RAM et MILANO
Tejidos COR, RAM y MILANO





1



2



ACCOPIAMENTO TESTA / TESTA
HEAD / HEAD COUPLING
COUPLAGE TÊTE / TÊTE
ACLOPAMIENTO CABEZA / CABEZA

ACCOPIAMENTO TESTA / PIEDI
HEAD / FEET COUPLING
COUPLAGE TÊTE / PIEDS
ACLOPAMIENTO CABEZA / PIE

4 POSIZIONI
4 POSITIONS

4

 misura/ sizes



n.2 Materassini filtranti tessuto Milano,
spessore 10 cm
n.2 Cuscini filtranti tra i lettini tessuto Milano,
spessore 10 cm

n.2 Filtering mattresses with Milano canvas,
thickness 10 cm
n.2 Filtering cushions between the sunbeds,
with Milano canvas, thickness 10 cm

n.2 Matelas filtrants en toile Milano
n.2 Coussins filtrants entre les transats,
en toile Milano, épaisseur 10 cm

n.2 Colchonetas filtrantes de tela Milano,
espesor 10 cm
n.2 Cojines filtrantes entre las camas en
tejido Milano de 10 cm de espesor



TWICE

p. 128

Finiture in alluminio
Aluminium finishes
Finitions en aluminium
Acabados de aluminio

p. 139

Tessuto MILANO
MILANO canvas
Toile MILANO
Tejido MILANO

it / Struttura in alluminio verniciato bianco. Ferramenta in acciaio inox AISI 316.

en / Aluminum structure powder coated in white color. Hardware in AISI 316 stainless steel.

fr / Structure en aluminium de couleur blanche avec des poudres époxy. Quincaillerie en acier inoxydable AISI 316.

es / Estructura de aluminio pintado de blanco. Herrajes en acero inoxidable AISI 316.

4 POSIZIONI
4 POSITIONS



LETTINI IN ALLUMINIO: LE MISURE
 ALUMINIUM SUNBEDS: THE SIZES
 TRANSAT EN ALUMINIUM : LES MESURES
 TUMBONAS DE ALUMINIO: LAS MEDIDAS

* Lettini per persone disabili h 50 cm
 * Sunbeds for disabled people h 50 cm
 * Transats pour personnes à mobilité réduite
 * Tumbonas para personas con discapacidades

STANDARD

YOUNG KOMMODO
 BASE SUPERIOR
 BASE 3P RICCIONE
 T3 RIO
 T3 NEW 5 STELLE
 T4

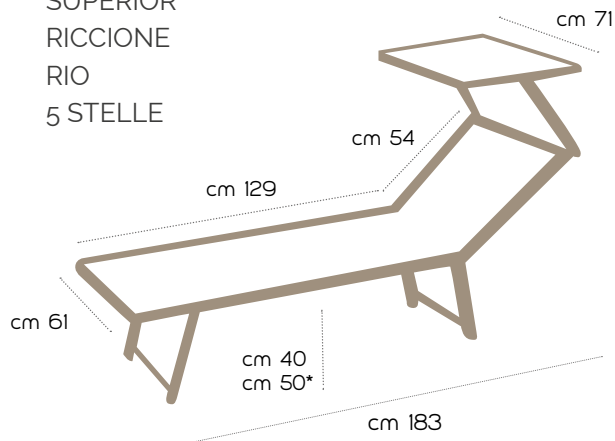

EXTRALONG

BASE SUPERIOR
 BASE 3P RICCIONE
 T3 RIO
 T3 NEW 5 STELLE
 T4 KOMMODO

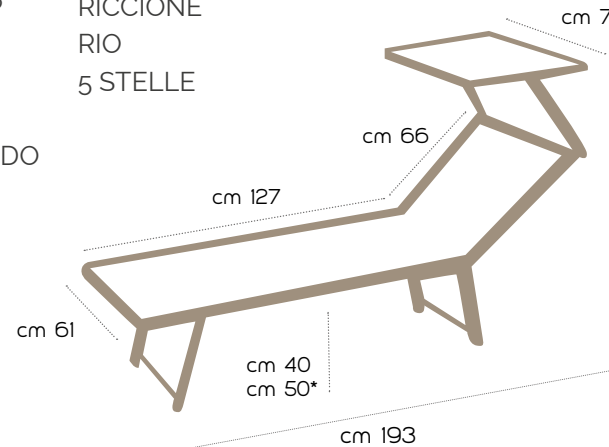

MIAMI

T3
 T3 NEW
 T4
 KOMMODO
 RIO

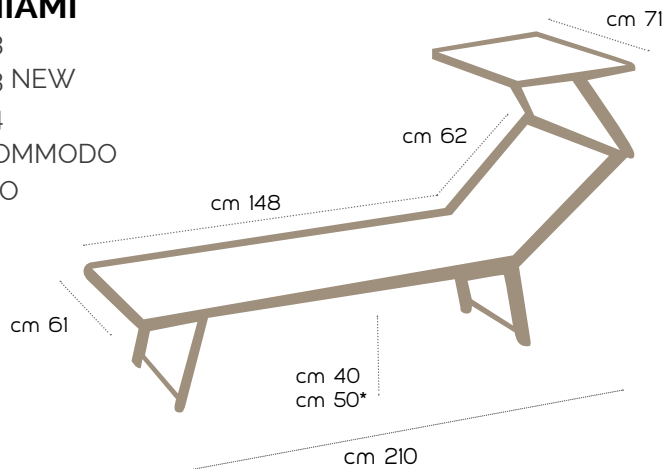

KINGSIZE

RICCIONE
 RIO

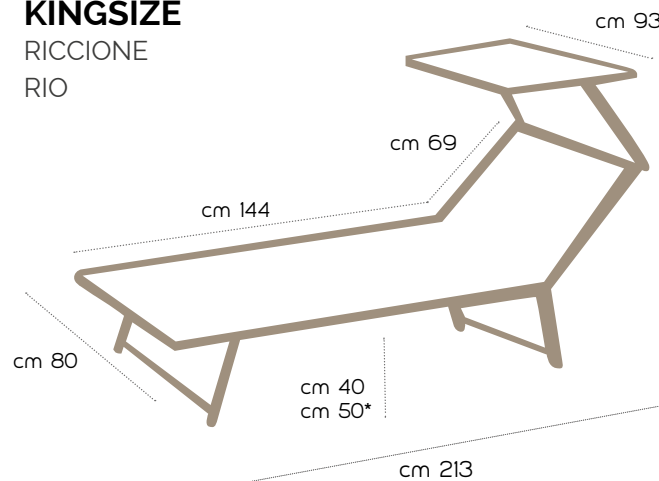

VIP

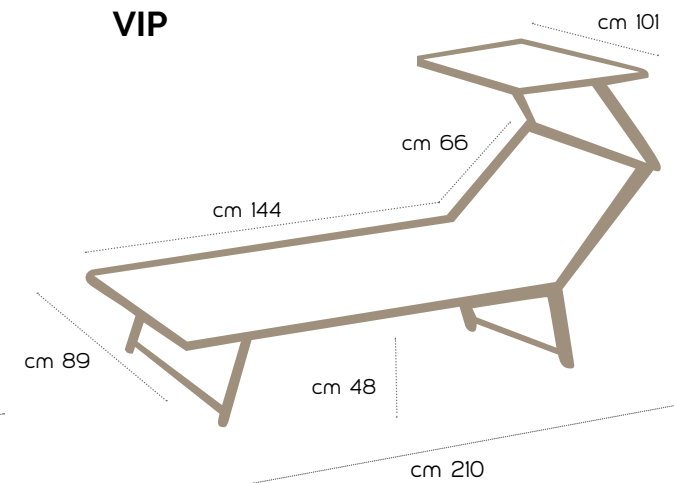

STANDARD

YOUNG KOMMODO
 BASE SUPERIOR
 BASE 3P RICCIONE
 T3 RIO
 T3 NEW 5 STELLE
 T4

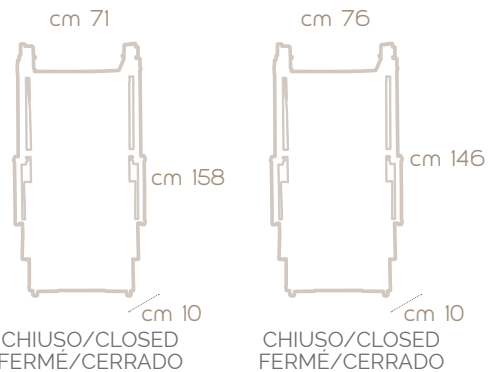

KING SIZE

RICCIONE
 RIO
 80

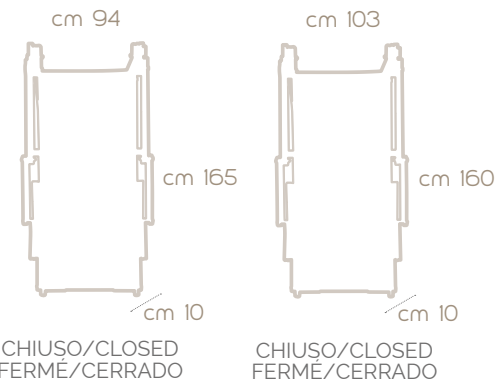

VIP

it / Tutti i lettini possono essere richiesti **con o senza tettuccio parasole.**
 en / All sunbeds can be requested **with or without the sunshield.**
 fr / Tous les transats peuvent être demandés **avec ou sans pare-soleil.**
 es / Todas las tumbonas pueden pedirse **con o sin parasol.**

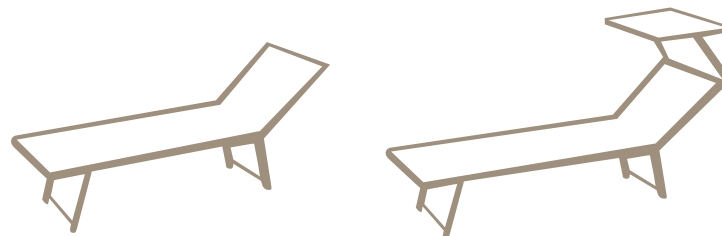

Letto chiuso.
 Sunbed closed.
 Transat fermé.
 Tumbona cerrada.



Mod. T3:
 Ingombro dei lettini impilati.
 Encumbrance of stacked sunbeds.
 Encombrement des transats empilés.
 Tamaño de las tumbonas apiladas.



Mod. Superior:
 Ingombro dei lettini impilati.
 Encumbrance of stacked sunbeds.
 Encombrement des transats empilés.
 Tamaño de las tumbonas apiladas.

it / I lettini **Vip**, e i lettini **Riccione e Rio** in **versione King Size** sono disponibili con tessuti COR o RAM.

en / The Vip sunbeds, and the Riccione and Rio sunbeds in the "King Size" version are available with COR or RAM canvas.

fr / Les transats VIP, et les transats Riccione et Rio en version «King Size» sont disponibles avec toile COR ou RAM.

es / Las tumbonas **Vip, Riccione y Rio** pueden pedirse en **tamaño King Size**. Disponible con tejidos COR o RAM.



VIP

versione/version
KINGSIZE

versione/version
STANDARD

it / Minimo ingombro durante il rimessaggio invernale.
Il tettuccio del lettino chiuso deve essere girato come in foto.

en / Minimum space requirement during winter storage.
The sunshield of the closed sunbed has to be turned as shown in the photo.

fr / Encombrement minimal pendant le stockage hivernal.
Le pare-soleil du transat fermé doit être tourné comme sur la photo.

es / Espacio mínimo durante el almacenamiento de invierno.
El parasol de la tumbona cerrada debe ser girado como en la foto.



it / Ramberti Point a Cisterna di Latina (Roma) Italia.
en / Ramberti Point in Cisterna di Latina (Rome) Italy.
fr / Ramberti Point à Cisterna di Latina (Rome) Italie.
es / Ramberti Point en Cisterna di Latina (Roma) Italia.

 misura/ sizes

 vedi pagina 20
see page 20
voir page 20
ver página 20

 pieghevole
folding
pliable
plegable

 L 160 cm
P 76 cm
H 11 cm
Kg 12
1 pz

 L 160 cm
P 80 cm
H 205 cm
Kg 285
25 pz

**OPZIONI / OPTIONS /
OPTIONNEL / OPTIONES:**

Cuscino/Cushion/Coussin/Cojin
50x25 cm, h 3 cm

Materassino/Mattress/Matelas/Colchoneta
180x60, 190x60, 180x80 cm / h 3-5 cm

REGOLAZIONE SCHIENALE TRAMITE CORDELLA
BACKREST ADJUSTMENT BY ROPE
RÉGLAGE DU DOSSIER AVEC CORDON
AJUSTE DEL RESPALDO MEDIANTE SISTEMA DE CORDÓN



BASE 3P

it / Lettino a 3 posizioni, con cordella. L'ultima inclinazione permette un allineamento totalmente orizzontale del lettino, rendendo possibile una confortevole posizione supina. Disponibile con o senza tettuccio parasole. Telaio in alluminio. Tessuto in pvc. Ferramenta inox AISI 316.

en / Sunbed with 3 inclinations of the backrest. The last inclination allows a totally horizontal alignment of the sunbed, making possible a comfortable supine position. Available with or without sunshield. Aluminium frame. Pvc canvas. Hardware Inox AISI 316.

fr / Transat à 3 positions, avec cordon. La dernière inclinaison permet un alignement totalement horizontal du transat permettant une position allongée confortable. Disponible avec ou sans pare-soleil. Structure en aluminium. Toile en pvc. Quincaillerie en acier inoxydable AISI 316.

es / Tumbona de 3 posiciones, con cordón. La última inclinación permite una alineación totalmente horizontal de la tumbona, haciendo posible una cómoda posición supina. Disponible con o sin parasol. Estructura de aluminio. Tejido de pvc. Herrajes de acero inoxidable AISI 316.

p. 128

Finiture in alluminio
Aluminium finishes
Finitions en aluminium
Acabados de aluminio

p. 132-133-135-136-138

Tessuti ROMAGNA, COR e RAM
ROMAGNA, COR and RAM canvases
Toiles ROMAGNA, COR et RAM
Tejidos ROMAGNA, COR y RAM

3 POSIZIONI
3 POSITIONS

3

 misura/ sizes

 vedi pagina 20
see page 20
voir page 20
ver página 20

 pieghevole
folding
pliable
plegable

 L 160 cm
P 76 cm
H 11 cm
Kg 12
1 pz

 L 160 cm
P 80 cm
H 205 cm
Kg 285
25 pz

**OPZIONI / OPTIONS /
OPTIONNEL / Opciones:**

Cuscino/Cushion/Coussin/Cojín
50x25 cm, h 3 cm

Materassino/Mattress/Matelas/Colchoneta
180x60, 190x60, 180x80 cm / h 3-5 cm

p. 128

Finiture in alluminio
Aluminium finishes
Finitions en aluminium
Acabados de aluminio

p. 132-133-135-136-138

Tessuti ROMAGNA, COR e RAM
ROMAGNA, COR and RAM canvases
Toiles ROMAGNA, COR et RAM
Tejidos ROMAGNA, COR y RAM

REGOLAZIONE SCHIENALE TRAMITE CORDELLA
BACKREST ADJUSTMENT BY ROPE
RÉGLAGE DU DOSSIER AVEC CORDON
AJUSTE DEL RESPALDO MEDIANTE SISTEMA DE CORDÓN



YOUNG

it / Lettino a 3 posizioni, con cordella. L'ultima inclinazione permette un allineamento totalmente orizzontale del lettino, rendendo possibile una confortevole posizione supina. Disponibile con o senza tettuccio parasole. Telaio in alluminio. Tessuto in pvc. Ferramenta inox AISI 316.

en / Sunbed with 3 inclinations of the backrest. The last inclination allows a totally horizontal alignment of the sunbed, making possible a comfortable supine position. Available with or without sunshield. Aluminium frame. Pvc canvas. Hardware Inox AISI 316.

fr / Transat à 3 positions, avec cordon. La dernière inclinaison permet un alignement totalement horizontal du transat permettant une position allongée confortable. Disponible avec ou sans pare-soleil. Structure en aluminium. Toile en pvc. Quincaillerie en acier inoxydable AISI 316.

es / Tumbona de 3 posiciones, con cordón. La última inclinación permite una alineación totalmente horizontal de la tumbona, haciendo posible una cómoda posición supina. Disponible con o sin parasol. Estructura de aluminio. Tejido de pvc. Herrajes de acero inoxidable AISI 316.



3 POSIZIONI
3 POSITIONS

3

 misure/ sizes

 vedi pagina 20
see page 20
voir page 20
ver página 20

 pieghevole
folding
pliable
plegable

 L 160 cm
P 76 cm
H 11 cm
Kg 12
1 pz

 L 160 cm
P 80 cm
H 205 cm
Kg 285
25 pz

OPZIONI / OPTIONS / OPTIONNEL / OPTIONNES:

Cuscino/Cushion/Coussin/Cojín
50x25 cm, h 3 cm

Materassino/Mattress/Matelas/Colchoneta
180x60, 190x60, 180x80 cm / h 3-5 cm

Ruote/Wheels/Roulettes/Ruedas

REGOLAZIONE SCHIENALE TRAMITE CORDELLA
BACKREST ADJUSTMENT BY ROPE
RÉGLAGE DU DOSSIER AVEC CORDON
AJUSTE DEL RESPALDO MEDIANTE SISTEMA DE CORDÓN



T3

it / Lettino a 3 posizioni con cordella. L'ultima inclinazione permette un allineamento totalmente orizzontale del lettino, rendendo possibile una confortevole posizione supina. Disponibile con o senza tettuccio parasole. Telaio in alluminio. Tessuto in pvc. Ferramenta inox AISI 316.

en / Traditional sunbed with 3 inclinations of the backrest, with rope. The third inclination allows a totally horizontal alignment of the sunbed, making possible a comfortable supine position. Available with or without sunshield. Aluminium frame. Pvc canvas. Hardware Inox AISI 316.

fr / Transat à 3 positions, avec cordon. La dernière inclinaison permet un alignement totalement horizontal du transat, permettant une position allongée confortable. Disponible avec ou sans pare-soleil. Structure en aluminium. Toile en pvc. Quincaillerie en acier inoxydable AISI 316.

es / Tumbona de 3 posiciones con cordón. La última inclinación permite una alineación totalmente horizontal de la tumbona, haciendo posible una cómoda posición supina. Disponible con o sin parasol. Estructura de aluminio. Tejido de pvc. Herrajes de acero inoxidable AISI 316.



3 POSIZIONI
3 POSITIONS

3

p. 128

Finiture in alluminio
Aluminium finishes
Finitions en aluminium
Acabados de aluminio

p. 132-133-135-136-138

Tessuti ROMAGNA, COR e RAM
ROMAGNA, COR and RAM canvases
Toiles ROMAGNA, COR et RAM
Tejidos ROMAGNA, COR y RAM



 misure/ sizes

 vedi pagina 20
see page 20
voir page 20
ver página 20

 pieghevole
folding
pliable
plegable

 L 160 cm
P 76 cm
H 11 cm
Kg 12
1 pz

 L 160 cm
P 80 cm
H 205 cm
Kg 285
25 pz

OPZIONI / OPTIONS / OPTIONNEL / OPTIONNES:

Cuscino/Cushion/Coussin/Cojin
50x25 cm, h 3 cm

Materassino/Mattress/Matelas/Colchoneta
180x60, 190x60, 180x80 cm / h 3-5 cm

Ruote/Wheels/Roulettes/Ruedas



p. 128

Finiture in alluminio
Aluminium finishes
Finitions en aluminium
Acabados de aluminio

p. 132-133-135-136-138

Tessuti ROMAGNA, COR e RAM
ROMAGNA, COR and RAM canvases
Toiles ROMAGNA, COR et RAM
Tejidos ROMAGNA, COR y RAM

28

NORMAL SUPERIOR



REGOLAZIONE SCHIENALE TRAMITE CORDELLA
BACKREST ADJUSTMENT BY ROPE
RÉGLAGE DU DOSSIER AVEC CORDON
AJUSTE DEL RESPALDO MEDIANTE SISTEMA DE CORDÓN



- it / Meccanismo esclusivo a molla che consente un ristretto spazio di stivaggio.
- en / Exclusive spring mechanism that allows for a small storage space.
- fr / Mécanisme à ressort exclusif qui permet un petit espace de rangement.
- es / Exclusivo mecanismo de resorte que permite un pequeño espacio de estiba.

SUPERIOR

- it / Lettino a 3 posizioni con cordella. L'ultima inclinazione permette un allineamento totalmente orizzontale del lettino, rendendo possibile una confortevole posizione supina. Disponibile con o senza tettuccio parasole. Telaio in alluminio. Tessuto in pvc. Ferramenta inox AISI 316.
- en / Traditional sunbed with 3 inclinations of the backrest, with rope. The third inclination allows a totally horizontal alignment of the sunbed, making possible a comfortable supine position. Available with or without sunshield. Aluminium frame. Pvc canvas. Hardware Inox AISI 316.
- fr / Transat à 3 positions, avec cordon. La dernière inclinaison permet un alignement totalement horizontal du transat, permettant une position allongée confortable. Disponible avec ou sans pare-soleil. Structure en aluminium. Toile en pvc. Quincaillerie en acier inoxydable AISI 316.
- es / Tumbona de 3 posiciones con cordón. La última inclinación permite una alineación totalmente horizontal de la tumbona, haciendo posible una cómoda posición supina. Disponible con o sin parasol. Estructura de aluminio. Tejido de pvc. Herrajes de acero inoxidable AISI 316.

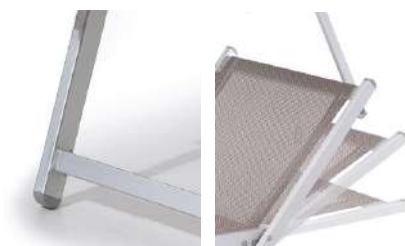

3 POSIZIONI
3 POSITIONS

3



 misure/ sizes

 vedi pagina 20
see page 20
voir page 20
ver página 20

 pieghevole
folding
pliable
plegable

 L 160 cm
P 76 cm
H 11 cm
Kg 12
1 pz

 L 160 cm
P 80 cm
H 205 cm
Kg 285
25 pz

OPZIONI / OPTIONS / OPTIONNEL / OPTIONNES:

Cuscino/Cushion/Coussin/Cojin
50x25 cm, h 3 cm

Materassino/Mattress/Matelas/Colchoneta
180x60, 190x60, 180x80 cm / h 3-5 cm

Ruote/Wheels/Roulettes/Ruedas

REGOLAZIONE SCHIENALE TRAMITE CORDELLA
BACKREST ADJUSTMENT BY ROPE
RÉGLAGE DU DOSSIER AVEC CORDON
AJUSTE DEL RESPALDO MEDIANTE SISTEMA DE CORDÓN



T4

it / Lettino a 4 posizioni dello schienale con cordella. La prima posizione consente di erigere lo schienale ad angolo retto e permette all'utilizzatore di sedersi comodamente appoggiando la schiena a mò di poltroncina. L'ultima inclinazione permette un allineamento totalmente orizzontale del lettino, rendendo possibile una confortevole posizione supina. Disponibile con o senza tettuccio parasole. Telaio in alluminio. Tessuto in pvc. Ferramenta inox AISI 316.

en / Sunbed with 4 inclinations of the backrest, with rope. The first inclination allows the backrest to be erected at a right angle and allows the user to sit comfortably leaning his back as a kind of armchair. The fourth inclination allows a totally horizontal alignment of the sunbed, making possible a comfortable supine position. Aluminium frame. Pvc canvas. Available with or without sunshield. Hardware Inox AISI 316.

fr / Transat à 4 positions, avec cordon. La première position permet de redresser le dossier à angle droit et permet à l'utilisateur de s'asseoir confortablement en adossant son dos comme un fauteuil. Avec la dernière position, il y a un alignement parfait du dossier avec le reste du transat, ce qui permet une position couchée confortable. Structure en aluminium. Toile en pvc. Disponible avec ou sans pare-soleil. Quincaillerie en acier inoxydable AISI 316.

es / Tumbona con respaldo de 4 posiciones con cordón. La primera posición permite levantar el respaldo en ángulo recto y que el usuario pueda sentarse cómodamente con la espalda apoyada como si fuera un sillón. En la última posición, el respaldo está perfectamente alineado con el resto de la tumbona, lo que hace posible una cómoda posición supina. Estructura de aluminio. Tejido de pvc. Disponible con o sin parasol. Herrajes de acero inoxidable AISI 316.



4 POSIZIONI
4 POSITIONS



p. 128

Finiture in alluminio
Aluminium finishes
Finitions en aluminium
Acabados de aluminio

p. 132-133-135-136-138

Tessuti ROMAGNA, COR e RAM
ROMAGNA, COR and RAM canvases
Toiles ROMAGNA, COR et RAM
Tejidos ROMAGNA, COR y RAM

 misura/ measures



vedi pagina 20
see page 20
voir page 20
ver página 20



pieghevole
folding
pliable
plegable



1 pz

L 160 cm
P 76 cm
H 11 cm
Kg 12



23 pz

L 160 cm
P 80 cm
H 205 cm
Kg 260

OPZIONI / OPTIONS / OPTIONNEL / OPTIONNES:

Cuscino/Cushion/Coussin/Cojin
50x25 cm, h 3 cm

Materassino/Mattress/Matelas/Colchoneta
180x60, 190x60, 180x80 cm / h 3-5 cm

Ruote/Wheels/Roulettes/Ruedas

REGOLAZIONE SCHIENALE CON MECCANISMO SENZA CORDELLA
BACKREST ADJUSTMENT WITH ROPELESS MECHANISM
RÉGLAGE DU DOSSIER AVEC MÉCANISME SANS CORDON
AJUSTE DEL RESPALDO CON MECANISMO SIN CORDÓN



T3 NEW

it / Lettino con 3 posizioni dello schienale con meccanismo salvadita. L'ultima inclinazione permette un allineamento totalmente orizzontale del lettino, rendendo possibile una confortevole posizione supina. Disponibile con o senza tettuccio parasole. Telaio in alluminio. Tessuto in pvc. Ferramenta inox AISI 316.

en / Sunbed with 3 inclinations of the backrest with finger guard system. The third inclination renders the sun lounger fully horizontal. Available with or without sunshield. Aluminium frame. Pvc canvas. Hardware Inox AISI 316.

fr / Transat à 3 positions avec système de protége-doigts. La dernière inclinaison permet un alignement totalement horizontal du transat, permettant une position allongée confortable. Disponible avec ou sans pare-soleil. Structure en aluminium. Toile en pvc. Quincaillerie en acier inoxydable AISI 316.

es / Tumbona con respaldo ajustable en 3 posiciones con mecanismo protector de dedos. La última inclinación permite una alineación totalmente horizontal de la tumbona, haciendo posible una cómoda posición supina. Disponible con o sin parasol. Estructura de aluminio. Tejido de pvc. Herrajes de acero inoxidable AISI 316.

MECCANISMO SALVADITA
FINGER GUARD SYSTEM
SYSTÈME DE PROTÈGE-
DOIGTS
SISTEMA DE PROTECCIÓN
DE DEDOS



3 POSIZIONI
3 POSITIONS

3

p. 128

Finiture in alluminio
Aluminium finishes
Finitions en aluminium
Acabados de aluminio

p. 132-133-135-136-138

Tessuti ROMAGNA, COR e RAM
ROMAGNA, COR and RAM canvases
Toiles ROMAGNA, COR et RAM
Tejidos ROMAGNA, COR y RAM

 misure/ sizes

 vedi pagina 20
see page 20
voir page 20
ver página 20

 pieghevole
folding
pliable
plegable

 L 160 cm
P 76 cm
H 11 cm
Kg 12
1 pz

 L 160 cm
P 80 cm
H 205 cm
Kg 285
25 pz

OPZIONI / OPTIONS / OPTIONNEL / OPTIONES:

Cuscino/Cushion/Coussin/Cojin
50x25 cm, h 3 cm

Materassino/Mattress/Matelas/Colchoneta
180x60, 190x60, 180x80 cm / h 3-5 cm

Ruote/Wheels/Roulettes/Ruedas

REGOLAZIONE SCHIENALE CON MECCANISMO SENZA CORDELLA
BACKREST ADJUSTMENT WITH ROPELESS MECHANISM
RÉGLAGE DU DOSSIER AVEC MÉCANISME SANS CORDON
AJUSTE DEL RESPALDO CON MECANISMO SIN CORDÓN



KOMMODO

it / Lettino con meccanismo salvadita che permette 4 diverse posizioni dello schienale rimanendo comodamente distesi sul lettino. E' possibile, infatti, agire sulle manopole di cui il lettino è provvisto, per posizionare lo schienale nella maniera desiderata. Disponibile con o senza tettuccio parasole. Telaio in alluminio. Tessuto pvc. Ferramenta inox AISI 316.

en / Sunbed with finger guard system that allows 4 different positions of the backrest while remaining comfortably lying on the sunbed. It is possible, in fact, to act on the levers with which the sunbed is provided to position the backrest in the desired one. Available with or without sunshield. Aluminium frame. Pvc canvas. Hardware Inox AISI 316.

fr / Transat avec système de protège-doigts qui permet 4 positions différentes du dossier tout en restant confortablement allongé sur le transat, car il est possible d'agir sur les molettes dont le transat est équipé, pour régler le dossier de la manière souhaitée. Disponible avec ou sans parasoleil. Structure en aluminium. Toile en pvc. Quincaillerie en acier inoxydable AISI 316.

es / Tumbona con mecanismo protector de dedos con respaldo ajustable en 4 posiciones diferentes mientras se está cómodamente tumbado en la misma. De hecho, es posible actuar sobre los pomos con los que está equipada la tumbona para colocar el respaldo de la manera deseada. Disponible con o sin parasol. Estructura de aluminio. Tejido de pvc. Herrajes de acero inoxidable AISI 316.

MECCANISMO SALVADITA
FINGER GUARD SYSTEM
SYSTÈME DE PROTÈGE-
DOIGTS
SISTEMA DE PROTECCIÓN
DE DEDOS



4 POSIZIONI
4 POSITIONS

4

p. 128

Finiture in alluminio
Aluminium finishes
Finitions en aluminium
Acabados de aluminio

p. 132-133-135-136-138

Tessuti ROMAGNA, COR e RAM
ROMAGNA, COR and RAM canvases
Toiles ROMAGNA, COR et RAM
Tejidos ROMAGNA, COR y RAM

 misure/ sizes

 vedi pagina 20
see page 20
voir page 20
ver página 20

 pieghevole
folding
pliable
plegable

 L 160 cm
P 76 cm
H 11 cm
Kg 12
1 pz

 L 160 cm
P 80 cm
H 205 cm
Kg 285
25 pz

OPZIONI / OPTIONS / OPTIONNEL / OPTIONNES:

Cuscino/Cushion/Coussin/Cojin
50x25 cm, h 3 cm

Materassino/Mattress/Matelas/Colchoneta
180x60, 190x60, 180x80 cm / h 3-5 cm

Ruote/Wheels/Roulettes/Ruedas

REGOLAZIONE SCHIENALE CON MECCANISMO SENZA CORDELLA
BACKREST ADJUSTMENT WITH ROPELESS MECHANISM
RÉGLAGE DU DOSSIER AVEC MÉCANISME SANS CORDON
AJUSTE DEL RESPALDO CON MECANISMO SIN CORDÓN



RICCIONE

it / Lettino con meccanismo salvadita a cremagliera, con 4 posizioni dello schienale. L'ultima inclinazione permette un allineamento totalmente orizzontale del lettino. Disponibile con o senza tettuccio parasole. Telaio in alluminio. Tessuto in pvc. Ferramenta inox AISI 316.

en / Sunbed with save finger rack mechanism that allows to adjust 4 different backrest positions for maximum comfort. Starting from the horizontal position, it is possible to choose the other three by simply raising the backrest. Aluminium frame. Pvc canvas. Available with or without sunshield. Hardware Inox AISI 316.

fr / Transat avec 4 positions de dossier, avec mécanisme à crémaillère, avec système de protégé-digts, avec la dernière inclinaison qui permet un alignement totalement horizontal du transat. Disponible avec ou sans pare-soleil. Structure en aluminium. Toile en pvc. Quincaillerie en acier inoxydable AISI 316.

es / Tumbona con respaldo ajustable en 4 posiciones mediante mecanismo de cremallera con mecanismo protector de dedos. La última inclinación permite una alineación totalmente horizontal de la tumbona. Disponible con o sin parasol. Estructura de aluminio. Tejido de pvc. Herrajes de acero inoxidable AISI 316.

CARTER SALVADITA
MECCANISMO
A CREMAGLIERA

CARTER SAVE FINGERS
ROPELESS RACK
MECHANISM

CARTER DE SÉCURITÉ
MÉCANISME
À CRÉMAILLÈRE

PROTECCIÓN DE DEDOS
MECANISMO
DE CREMALLERA

4 POSIZIONI
4 POSITIONS

4

p. 128

Finiture in alluminio
Aluminium finishes
Finitions en aluminium
Acabados de aluminio

p. 132-133-135-136-138

Tessuti ROMAGNA, COR e RAM
ROMAGNA, COR and RAM canvases
Toiles ROMAGNA, COR et RAM
Tejidos ROMAGNA, COR y RAM

 misure / sizes

 vedi pagina 20
see page 20
voir page 20
ver página 20

 pieghevole
folding
pliable
plegable

REGOLAZIONE SCHIENALE CON MECCANISMO SENZA CORDELLA
BACKREST ADJUSTMENT WITH ROPELESS MECHANISM
RÉGLAGE DU DOSSIER AVEC MÉCANISME SANS CORDON
AJUSTE DEL RESPALDO CON MECANISMO SIN CORDÓN



OPZIONI / OPTIONS / OPTIONNEL / OPTIONNES:

Cuscino/Cushion/Coussin/Cojín
50x25 cm, h 3 cm

Materassino/Mattress/Matelas/Colchoneta
195X80 cm / h 3-5 cm

Ruote/Wheels/Roulettes/Ruedas

VIP

it / Lettino con 5 diverse posizioni dello schienale, con meccanismo salvadita a cremagliera, per un maggiore comfort. Partendo dalla posizione stesa è possibile scegliere le altre quattro alzando semplicemente lo schienale. Disponibile con o senza tettuccio parasole. Telaio in alluminio. Tessuto in pvc. Ferramenta inox AISI 316.

en / Sunbed with save finger rack mechanism that allows to adjust 5 different backrest positions for maximum comfort. Starting from the horizontal position, it is possible to choose the other four by simply raising the backrest. Available with or without sunshield. Aluminium frame. Pvc canvas. Hardware Inox AISI 316.

fr / 5 positions différentes du dossier avec mécanisme à crémaillère, avec système de protège-digts, pour plus de confort. A partir de la position allongée, il est possible de choisir les quatre autres en relevant simplement le dossier. Disponible avec ou sans pare-soleil. Structure en aluminium. Toile en pvc. Quincaillerie en acier inoxydable AISI 316.

es / Respaldo ajustable en 5 posiciones diferentes con mecanismo de cremallera, con mecanismo protector de dedos, para mayor comodidad. Partiendo de la posición tumbada, es posible elegir las otras cuatro simplemente levantando el respaldo. Disponible con o sin parasol. Estructura de aluminio. Tejido de pvc. Herrajes de acero inoxidable AISI 316.

CARTER DE SÉCURITÉ
MÉCANISME
À CRÉMAILLÈRE

PROTECCIÓN DE DEDOS
MECANISMO
DE CREMALLERA

CARTER SALVADITA
MECCANISMO
A CREMAGLIERA

CARTER SAVE FINGERS
ROPELESS RACK
MECHANISM

4 POSIZIONI
4 POSITIONS

4

p. 128

Finiture in alluminio
Aluminium finishes
Finitions en aluminium
Acabados de aluminio

p. 132-133-135-136-138

Tessuti ROMAGNA, COR e RAM
ROMAGNA, COR and RAM canvases
Toiles ROMAGNA, COR et RAM
Tejidos ROMAGNA, COR y RAM

 misure / sizes

 vedi pagina 20
see page 20
voir page 20
ver página 20

 pieghevole
folding
pliable
plegable

 L 160 cm
P 76 cm
H 11 cm
Kg 12
1 pz

 L 160 cm
P 80 cm
H 205 cm
Kg 285
25 pz

OPZIONI / OPTIONS / OPTIONNEL / OPTIONNES:

Cuscino / Cushion / Coussin / Cojín
50x25 cm, h 3 cm

Materassino / Mattress / Matelas / Colchoneta
180x60, 190x60, 180x80 cm / h 3-5 cm

Ruote / Wheels / Roulettes / Ruedas

REGOLAZIONE SCHIENALE CON MECCANISMO SENZA CORDELLA
BACKREST ADJUSTMENT WITH ROPELESS MECHANISM
RÉGLAGE DU DOSSIER AVEC MÉCANISME SANS CORDON
AJUSTE DEL RESPALDO CON MECANISMO SIN CORDÓN



5 STELLE

- it / Lettino con 5 diverse posizioni dello schienale, con meccanismo salvadita a cremagliera, per un maggiore comfort. Partendo dalla posizione stesa è possibile scegliere le altre quattro alzando semplicemente lo schienale. Disponibile con o senza tettuccio parasole. Telaio in alluminio. Tessuto in pvc. Ferramenta inox AISI 316.
- en / Sunbed with save finger rack mechanism that allows to adjust 5 different backrest positions for maximum comfort. Starting from the horizontal position, it is possible to choose the other four by simply raising the backrest. Available with or without sunshield. Aluminium frame. Pvc canvas. Hardware Inox AISI 316.
- fr / 5 positions différentes du dossier avec mécanisme à crémaillère, avec système de protège-digts, pour plus de confort. A partir de la position allongée, il est possible de choisir les quatre autres en relevant simplement le dossier. Disponible avec ou sans pare-soleil. Structure en aluminium. Toile en pvc. Quincaillerie en acier inoxydable AISI 316.
- es / Respaldo ajustable en 5 posiciones diferentes con mecanismo de cremallera, con mecanismo protector de dedos, para mayor comodidad. Partiendo de la posición tumbada, es posible elegir las otras cuatro simplemente levantando el respaldo. Disponible con o sin parasol. Estructura de aluminio. Tejido de pvc. Herrajes de acero inoxidable AISI 316.

CARTER DE SÉCURITÉ
MÉCANISME
À CRÉMAILLÈRE

PROTECCIÓN DE DEDOS
MECANISMO
DE CREMALLERA

CARTER SALVADITA
MECCANISMO
A CREMAGLIERA

CARTER SAVE FINGERS
ROPELESS RACK
MECHANISM

5 POSIZIONI
5 POSITIONS

5 

p. 128

Finiture in alluminio
Aluminium finishes
Finitions en aluminium
Acabados de aluminio

p. 132-133-135-136-138

Tessuti ROMAGNA, COR e RAM
ROMAGNA, COR and RAM canvases
Toiles ROMAGNA, COR et RAM
Tejidos ROMAGNA, COR y RAM

 misure / sizes



vedi pagina 20
see page 20
voir page 20
ver página 20



pieghevole
folding
pliable
plegable



1 pz

L 160 cm
P 76 cm
H 11 cm
Kg 12



25 pz

L 160 cm
P 80 cm
H 205 cm
Kg 285

OPZIONI / OPTIONS / OPTIONNEL / OPTIONNES:

Cuscino/Cushion/Coussin/Cojín
50x25 cm, h 3 cm

Materassino/Mattress/Matelas/Colchoneta
180x60, 190x60, 180x80 cm / h 3-5 cm

Ruote/Wheels/Roulettes/Ruedas

REGOLAZIONE SCHIENALE CON MECCANISMO SENZA CORDELLA
BACKREST ADJUSTMENT WITH ROPELESS MECHANISM
RÉGLAGE DU DOSSIER AVEC MÉCANISME SANS CORDON
AJUSTE DEL RESPALDO CON MECANISMO SIN CORDÓN



CARTER DE SÉCURITÉ
MÉCANISME
À CRÉMAILLÈRE

PROTECCIÓN DE DEDOS
MECANISMO
DE CREMALLERA

CARTER SALVADITA
MECCANISMO
A CREMAGLIERA

CARTER SAVE FINGERS
ROPELESS RACK
MECHANISM

5 POSIZIONI
5 POSITIONS

5

RIO

- it / Lettino con 5 diverse posizioni dello schienale, con meccanismo salvadita a cremagliera, per un maggiore comfort. Partendo dalla posizione stesa è possibile scegliere le altre quattro alzando semplicemente lo schienale. Disponibile con o senza tettuccio parasole. Telaio in alluminio. Tessuto in pvc. Ferramenta inox AISI 316.
- en / Sunbed with save finger rack mechanism that allows to adjust 5 different backrest positions for maximum comfort. Starting from the horizontal position, it is possible to choose the other four by simply raising the backrest. Available with or without sunshield. Aluminium frame. Pvc canvas. Hardware Inox AISI 316.
- fr / 5 positions différentes du dossier avec mécanisme à crémaillère, avec système de protège-digts, pour plus de confort. A partir de la position allongée, il est possible de choisir les quatre autres en relevant simplement le dossier. Disponible avec ou sans pare-soleil. Structure en aluminium. Toile en pvc. Quincaillerie en acier inoxydable AISI 316.
- es / Respaldo ajustable en 5 posiciones diferentes con mecanismo de cremallera, con mecanismo protector de dedos, para mayor comodidad. Partiendo de la posición tumbada, es posible elegir las otras cuatro simplemente levantando el respaldo. Disponible con o sin parasol. Estructura de aluminio. Tejido de pvc. Herrajes de acero inoxidable AISI 316.

p. 128

Finiture in alluminio
Aluminium finishes
Finitions en aluminium
Acabados de aluminio

p. 132-133-135-136-138

Tessuti ROMAGNA, COR e RAM
ROMAGNA, COR and RAM canvases
Toiles ROMAGNA, COR et RAM
Tejidos ROMAGNA, COR y RAM



 misure/ sizes



vedi pagina 20
see page 20
voir page 20
ver página 20



pieghevole
folding
pliable
plegable



1 pz

L 160 cm
P 76 cm
H 11 cm
Kg 12



25 pz

L 160 cm
P 80 cm
H 205 cm
Kg 285

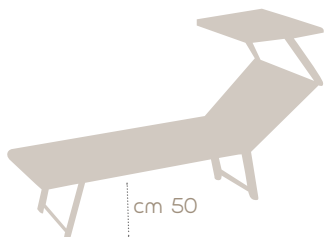

LETTINI PER PERSONE DISABILI

SUNBEDS FOR DISABLED PEOPLE

TRANSATS POUR PERSONNES À MOBILITÉ RÉDUITE

TUMBONAS PARA PERSONAS CON DISCAPACIDADES

it / I lettini T3, T4, SUPERIOR, T3 NEW, KOMMODO, RICCIONE, VIP, RIO, 5 STELLE possono essere richiesti con altezza seduta 50 cm.

en / The sunbeds models T3, T4, SUPERIOR, T3 NEW, KOMMODO, RICCIONE, VIP, RIO, 5 STELLE can be requested with a seat height of 50cm.

fr / Les transats T3, T4, SUPERIOR, T3 NEW, KOMMODO, RICCIONE, VIP, RIO, 5 STELLE peuvent être demandés avec une hauteur d'assise de 50 cm.

es / Las tumbonas T3, T4, SUPERIOR, T3 NEW, KOMMODO, RICCIONE, VIP, RIO, 5 STELLE se pueden pedir con una altura de asiento de 50 cm.



CARROZZINA MARE PER DISABILI

BEACH WHEELCHAIR FOR DISABLED PEOPLE

FAUTEUIL ROULANT DE PLAGE POUR PERSONNES À MOBILITÉ RÉDUITE

SILLA DE RUEDAS DE PLAYA PARA PERSONAS CON DISCAPACIDADES

 misure/ sizes



L 82 cm
P 88 cm
H 96 cm
Hs 54 cm



pieghevole
folding
pliable
plegable



1 pz

L 89 cm
P 31 cm
H 123 cm
Kg 19

it / Carrozzina da spiaggia a due ruote, ideale per lo spostamento sulla sabbia e per il bagno in mare con l'aiuto di un accompagnatore. Il telaio pieghevole è facile da trasportare e riporre quando non usato. Tessuto pvc Romagna 861 e 862. Ferramenta inox AISI 316.

en / Two-wheeled beach wheelchair, ideal for moving on the sand and for swimming in the sea with the help of an accompanying person. The foldable frame is easy to carry and store when it not in use. Pvc Romagna canvas 861 and 862. Hardware Inox AISI 316.

fr / Fauteuil roulant de plage à deux roues, idéale pour se déplacer sur le sable, et se baigner dans la mer avec l'aide d'un compagnon. La structure pliable est facile à transporter et à ranger lorsque la fauteuil n'est pas utilisée. Pvc Toile Romagna 861 et 862. Quincaillerie en acier inoxydable AISI 316.

es / Silla de ruedas de playa de dos ruedas, ideal para desplazarse por la arena y bañarse en el mar con la ayuda de un asistente. La estructura plegable es fácil de transportar y guardar cuando no se utiliza. Pvc tejido Romagna 861 y 862. Herrajes de acero inoxidable AISI 316.

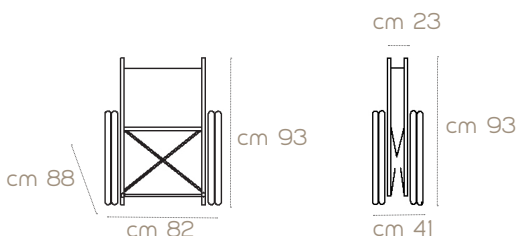

TESSUTI / FABRICS / TISSUS / TEJIDO



ROMAGNA 861



ROMAGNA 862



 misure/ sizes

 L 100 cm
P 61 cm
H 30 cm

 pieghevole
folding
pliable
plegable

p. 128

Finiture in alluminio
Aluminium finishes
Finitions en aluminium
Acabados de aluminio

p. 132-133-135-136-138

Tessuti ROMAGNA, COR e RAM
ROMAGNA, COR and RAM canvases
Toiles ROMAGNA, COR et RAM
Tejidos ROMAGNA, COR y RAM

 misura/ measures

Lunghezza rocche:
circa 500-600 metri
Peso singola rocca:
circa 1,5-2,5 Kg

Reel length:
about 500-600 meters
Single reel weight: approx.
1.5-2.5 Kg

Longueur de bobine :
environ 500-600 mètres
Poids du colis unique :
environ 1,5-2,5 kg

Longitud de la bobina:
aproximadamente 500-600
metros
Peso de una bobina:
aproximadamente 1,5-2,5 kg

BABY

- it / Lettino con telo in pvc. Telaio in alluminio.
- en / Sunbed with pvc canvas. Aluminum frame
- fr / Transat avec toile de pvc .Structure en aluminium.
- es / Cama con tela de pvc. Estructura de aluminio.



RUOTE WHEELS ROULETTES RUEDAS

- it / Le ruote sono applicabili ai lettini (a parte il modello BASE 3P E YOUNG) facilitandone lo spostamento, specialmente in aree Spa e piscine.
- en / The wheels can be applied to the sunbeds (a part the model BASE 3P and YOUNG) facilitating their movement, especially in SPA areas and swimming pools.
- fr / Les roulettes peuvent être appliquées sur les transats (à l'exception du modèle BASE 3P et YOUNG) facilitant leur déplacement, en particulier dans les espaces Spa et les piscines.
- es / Las ruedas se pueden acoplar a las tumbonas (aparte del modelo BASE 3P Y YOUNG), lo que facilita su desplazamiento, especialmente en las zonas de spa y piscina.



CORDELLE BRAIDED ROPES CORDONS CORDONES

- it / Treccia tonda 8 fili realizzata in filato di pvc. Si può utilizzare, per esempio, per sostituire le obsolete cordelle bianche, abbinando le stesse al colore del telo del lettino. Disponibile in tante varianti di colori.
- en / Round 8-wire braid made of pvc yarn. It can be used, for example, to replace the obsolete white ropes, matching them to the color of the sunbed fabric. Available in many color variants.
- fr / Tresse ronde à 8 brins en fil de pvc. Il peut être utilisé, par exemple, pour remplacer les cordons blancs obsolètes, en les assortissant à la couleur de la toile du transat. Disponible dans de nombreuses variations de couleurs.
- es / Trenza redonda de 8 hilos fabricada con hilo de pvc. Puede utilizarse, por ejemplo, para sustituir los obsoletos cordones blancos, haciéndolos coincidir con el color del tejido de la tumbona. Disponible en numerosas variaciones de color.



 misure/ measures

3 cm
spessore cuscino
cushion thickness
épaisseur du coussin
espesor del cojin

3 - 5 - 10 cm
spessore materassino
mattress thickness
épaisseur du matelas
espesor del colchoneta

Misure personalizzate su richiesta.
Customized measurements on request.
Mesures personnalisées sur demande.
Medidas personalizadas bajo pedido.



L 160 cm
P 76 cm
H 11 cm
Kg 10

2 pz (h 3-5 cm)



L 160 cm
P 80 cm
H 205 cm
Kg 190

34 pz (5cm)



L 175 cm
P 100 cm
H 22 cm
Kg 25

2 pz (10cm)



L 175 cm
P 100 cm
H 195 cm
Kg 225

16 pz (10cm)

CUSCINO E MATERASSINO FILTRANTI

FILTERING CUSHION AND MATTRESS

COUSSIN ET MATELAS FILTRANTS

COJÍN Y COLCHONETA FILTRANTES

- it / Materassino e cuscino realizzati con nostro tessuto.
Interno composto da una struttura tridimensionale di fibre in pvc simile a un blocco di spaghetti di plastica bianca.
Questo materiale consente di far filtrare l'acqua e di asciugarsi in brevissimo tempo. E' quindi possibile evitare di togliere il prodotto in caso di pioggia.
Il trattamento antimuffa del tessuto garantisce una durata prolungata nel tempo.
Completamente sfoderabile.
Possibilità di personalizzazione del tessuto (con loghi o scritte).
Colori disponibili: vedere cartella colori tessuto Milano.
Applicabile a tutti i modelli di lettino.
- en / Mattress and cushion covers are made with our fabric,
with the internal part composed of a three-dimensional structure of pvc white fibers,
that allows the water to filter and dry in a very short time.
It is therefore possible to avoid removing the mattress and the cushion when rain approaches.
The anti-mold treatment of the fabric guarantees a prolonged duration over time.
Fully removable.
Possibility of customizing the canvas (with logos or writings).
Available colors: see Milano fabrics color chart.
Applicable to all sunbed models.
- fr / Matelas et coussin fabriqués avec notre toile.
Intérieur composé d'une structure tridimensionnelle de fibres de pvc blanc.
Ce matériau permet à l'eau de filtrer et de sécher en très peu de temps.
Il est ainsi possible d'éviter de retirer le produit en cas de pluie.
Le traitement anti-moisissure du tissu garantit une durée prolongée dans le temps.
Entièrement déhoussable.
Possibilité de personnaliser le toile (avec logos ou écritures).
Coloris disponibles : voir nuancier tissu Milano.
Applicable sur tous les modèles de transat.
- es / Colchoneta y cojín fabricados con nuestro tejido.
Interior compuesto por una estructura tridimensional de fibras de pvc similar a un bloque de espaguetis de plástico blanco.
Este material permite que el agua se filtre y se seque en muy poco tiempo.
Por lo tanto, no es necesario retirar el producto en caso de lluvia.
El tratamiento antimoho del tejido garantiza una larga duración.
Forro totalmente desmontable.
Posibilidad de personalizar el tejido (con logotipos o letras).
Colores disponibles:
véase la lista de colores del tejido de Milano.
Aplicable a todos los modelos de tumbona.



p. 139
Tessuti MILANO
MILANO canvases
Toiles MILANO
Tejidos MILANO



it / Portaoggetti
 en / Storage compartment
 fr / Boîte à gants
 es / Portaobjetos



it / Misure personalizzate su richiesta.
 en / Customized measurements on request.
 fr / Mesures personnalisées sur demande.
 es / Medidas personalizadas bajo pedido.

 misure/ sizes



L 107 cm
P 58,5 cm
Hs 30 cm



pieghevole
folding
pliable
plegable



2 pz

L 160 cm
P 76 cm
H 11 cm
Kg 15



60 pz

L 150 cm
P 80 cm
H 205 cm
Kg 470

cm 58,5



cm 138

CHIUSO/CLOSED
FERMÉ/CERRADO



SDRAIO

SENZA BRACCIOLI
DECKCHAIR WITHOUT ARMS
CHILIENNE SANS ACCOUDOIRS
TUMBONA SIN REPOSABRAZOS

p. 128

Finiture in alluminio
Aluminium finishes
Finitions en aluminium
Acabados de aluminio

p. 132-133-135-136-138

Tessuti ROMAGNA, COR e RAM
ROMAGNA, COR and RAM canvases
Toiles ROMAGNA, COR et RAM
Tejidos ROMAGNA, COR y RAM

- it / Telaio in alluminio. Tessuto in pvc. Ferramenta inox AISI 316.
GLI SDRAI VENGONO FORNITI CON LE TELE A PARTE, NON MONTATE.
- en / Aluminum frame. pvc canvas. Hardware Inox AISI 316.
THE DECKCHAIRS ARE SUPPLIED WITH THE FABRIC SEPARATELY, NOT ASSEMBLED.
- fr / Structure en aluminium. Toile en pvc. Quincaillerie en acier inoxydable AISI 316.
LES CHILIENNES SONT FOURNIES AVEC LA TOILE SÉPARÉMENT, NON ASSEMBLÉES.
- es / Estructura de aluminio. Tejido de pvc. Herrajes de acero inoxidable AISI 316.
LAS TUMBONAS SE SUMINISTRAN CON LOS TEJIDOS POR SEPARADO, SIN MONTAR.



3 POSIZIONI
3 POSITIONS

3



 misura/ sizes



L 114 cm
P 68 cm
Hs 30 cm



pieghevole
folding
pliable
plegable



2 pz

L 160 cm
P 76 cm
H 11 cm
Kg 16



60 pz

L 150 cm
P 90 cm
H 205 cm
Kg 500

cm 68



cm 148



CHIUSO/CLOSED
FERME/CERRADO



p. 128

Finiture in alluminio
Aluminium finishes
Finitions en aluminium
Acabados de aluminio

p. 132-133-135-136-138

Tessuti ROMAGNA, COR e RAM
ROMAGNA, COR and RAM canvases
Toiles ROMAGNA, COR et RAM
Tejidos ROMAGNA, COR y RAM

3 POSIZIONI
3 POSITIONS

3 

SDRAIO CON BRACCIOLI DECKCHAIR WITH ARMS CHILIENNE AVEC ACCOUDOIRS TUMBONA CON REPOSABRAZOS

- it / Telaio in alluminio. Tessuto in pvc. Ferramenta inox AISI 316.
GLI SDRAI VENGONO FORNITI CON LE TELE A PARTE, NON MONTATE.
- en / Aluminum frame. Pvc canvas. Hardware Inox AISI 316.
THE DECKCHAIRS ARE SUPPLIED WITH THE FABRIC SEPARATELY, NOT ASSEMBLED.
- fr / Structure en aluminium. Toile en pvc. Quincaillerie en acier inoxydable AISI 316.
LES CHILIENNES SONT FOURNIES AVEC LA TOILE SÉPARÉMENT, NON ASSEMBLÉES.
- es / Estructura de aluminio. Tejido de pvc. Herrajes de acero inoxidable AISI 316.
LAS TUMBONAS SE SUMINISTRAN CON LOS TEJIDOS POR SEPARADO, SIN MONTAR.



 misure/ sizes



L 63,5 cm
P 113 cm
H 112,5 cm
Hs 36 cm



pieghevole
folding
pliable
plegable



1 pz

L 112 cm
P 65 cm
H 12 cm
Kg 4,6



40 pz

L 120 cm
P 120 cm
H 190 cm
Kg 200

cm 64

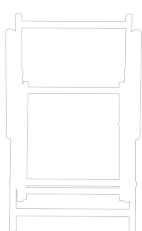

cm 107

cm 5

CHIUSO/CLOSED
FERMÉ/CERRADO



L 46 cm
P 45 cm
H 45 cm



pieghevole
folding
pliable
plegable

p. 128

Finiture in alluminio
Aluminium finishes
Finitions en aluminium
Acabados de aluminio

p. 132-133-135-136-138

Tessuti ROMAGNA, COR e RAM
ROMAGNA, COR and RAM canvas
Toile ROMAGNA, COR et RAM
Tejidos ROMAGNA, COR y RAM

MARINELLA e SGABELLO

it / Telaio in alluminio. Tessuto in pvc. Ferramenta inox AISI 316.

en / Aluminum frame. Pvc canvas. Hardware Inox AISI 316.

fr / Structure en aluminium. Toile en pvc. Quincaillerie en acier inoxydable AISI 316.

es / Estructura de aluminio. Tejido de pvc. Herrajes de acero inoxidable AISI 316.



2 POSIZIONI
2 POSITIONS

2

 misura/ sizes



L 196,5 cm
P 72/86,5 cm
H 35,5



impilabile
stackable
empilable
apilable



1 pz

L 166 cm
P 65 cm
H 9 cm
Kg 25,5



15 pz

L 200 cm
P 80 cm
H 150 cm
Kg 400

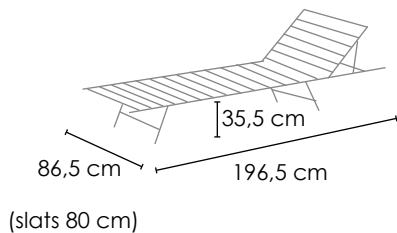
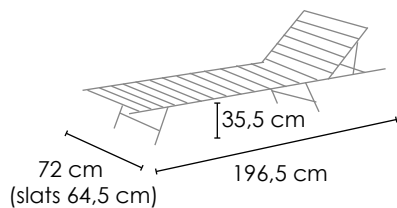

RELAX

p. 127

Finiture in legno
Wood finishes
Finitions du bois
Acabados de madera

p. 139

Tessuti MILANO per materassino
MILANO canvases for mattress
Toiles MILANO pour matelas
Tejidos MILANO para colchoneta

- it / Lettino con struttura a doghe in legno di frassino.
6 inclinazioni dello schienale, con scaletta. Con materassino filtrante h.10 cm.
Ferramenta inox AISI 316.
- en / Sunbed with wooden slats, with structure in ash wood.
6 ropeless backrest inclinations by ladder, with filtering mattress h 10 cm.
Hardware Inox AISI 316.
- fr / Transat avec structure à lattes en bois de frêne.
6 inclinaisons de dossier avec échelle. Avec matelas filtrant h.10 cm.
Quincaillerie en acier inoxydable AISI 316.
- es / Tumbona con estructura listones de madera de fresno.
Respaldo reclinable en 6 niveles diferentes. Con colchoneta filtrante de 10 cm de altura.
Herrajes de acero inoxidable AISI 316.



6 POSIZIONI
6 POSITIONS

6





 misure/ sizes



L 196 cm
P 86,5 cm
H 33



impilabile
stackable
empilable
apilable



1 pz

L 196 cm
P 80 cm
H 7 cm
Kg 19,5



20 pz

L 200 cm
P 80 cm
H 160 cm
Kg 400

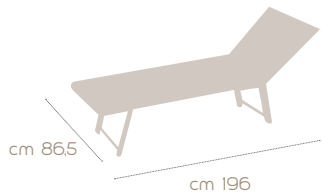

LUXURY

p. 127

Finiture in legno
Wood finishes
Finitions du bois
Acabados de madera

p. 128

Finiture in alluminio
Aluminium finishes
Finitions en aluminium
Acabados de aluminio

p. 135-136-138

Tessuti COR e RAM
COR and RAM canvas
Toile COR et RAM
Tejidos COR y RAM

it / Lettino con struttura in legno di frassino e struttura interna in alluminio verniciato.
6 inclinazioni dello schienale con scaletta. Tessuto in pvc. Ferramenta inox AISI 316.

en / Sunbed with structure in ash wood, and with internal structure in powder coated aluminum, with
6 ropeless backrest inclinations by ladder. Pvc canvas. Hardware Inox AISI 316

fr / Transat avec structure en bois de frêne et structure interne en aluminium peint avec des poudres
époxy. 6 inclinaisons de dossier avec échelle. Toile en pvc. Quincaillerie en acier inoxydable AISI
316.

es / Tumbona con estructura de madera de fresno y estructura interior de aluminio pintado.
6 inclinaciones de respaldo con niveles. Tejido de pvc. Herrajes de acero inoxidable AISI 316.



6 POSIZIONI
6 POSITIONS

6 



 misura/ sizes



L 196 cm
P 136 cm
H 33



impilabile
stackable
empilable
apilable



1 pz

L 200 cm
P 90 cm
H 40 cm
Kg 41



p. 127

Finiture in legno
Wood finishes
Finitions du bois
Acabados de madera

p. 128

Finiture in alluminio
Aluminium finishes
Finitions en aluminium
Acabados de aluminio

p. 135-136-138

Tessuti COR e RAM
COR and RAM canvas
Toile COR et RAM
Tejidos COR y RAM

DELUXE

- it / Lettino con struttura in legno di frassino e struttura interna in alluminio verniciato. 6 inclinazioni dello schienale con scaletta. Tessuto in pvc. Ferramenta inox AISI 316.
- en / Sunbed with structure in ash wood, and with internal structure in powder coated aluminum, with 6 ropeless backrest inclinations by ladder. Pvccanvas. Hardware Inox AISI 316
- fr / Transat avec structure en bois de frêne et structure interne en aluminium peint avec des poudres époxy. 6 inclinaisons de dossier avec échelle. Toile en pvc. Quincaillerie en acier inoxydable AISI 316.
- es / Tumbona con estructura de madera de fresno y estructura interior de aluminio pintado. 6 inclinaciones de respaldo con niveles. Tejido de pvc. Herrajes de acero inoxidable AISI 316.



6 POSIZIONI
6 POSITIONS

6 

 misure/ sizes

 L 198,5 cm
P 179,5 cm
H 43

 L 200 cm
P 90 cm
H 40 cm
Kg 46
1 pz



n.2 Materassini filtranti tessuto Milano, cad.
195x80 cm, spessore 10 cm
n.2 Cuscini filtranti tra i lettini tessuto Milano,
spessore 10 cm

n.2 Filtering mattresses with Milano fabric, each
195x80 cm, thickness 10 cm
n.2 Filtering cushions between the sunbeds, with
Milano fabric, thickness 10 cm

n.2 Matelas filtrants en tissu Milano, chacun
195x80 cm, épaisseur 10 cm
n.2 Coussins filtrants entre les transats, en tissu
Milano, épaisseur 10 cm

n.2 Colchonetas filtrantes de tela Milano, cada
una 195x80cm, espesor 10 cm
n.2 Cojines filtrantes entre las camas en tejido
Milano de 10 cm de espesor

COMBO

it / Struttura in legno di abete lamellare. Completo di 2 lettini a doghe in legno di frassino, della misura 196,5x86,5 cm, con 6 inclinazioni dello schienale, regolabile con scaletta. Ferramenta in acciaio inox AISI 316.

en / Structure made of lamellar fir wood. Included 2 sunbeds with ashwood slats, measuring 196,5x86,5 cm, with 6 backrest inclinations, by ladder. Hardware in AISI 316 stainless steel.

fr / Structure en bois de sapin lamellé. Compris 2 transats à lattes en frêne, mesurant 196,5x86,5 cm, avec 6 inclinaisons de dossier, avec échelle. Quincaillerie en acier inoxydable AISI 316.

es / Estructura en madera de abeto laminada. Completo con 2 tumbonas con listones de madera de fresno de 196,5x86,5 cm cada una con 6 posiciones de respaldo, mediante escalera. Herrajes en acero inoxidable AISI 316.

p. 127

Finiture in legno
Wood finishes
Finitions du bois
Acabados de madera

p. 139

Tessuti MILANO per materassino
MILANO canvases for mattress
Toiles MILANO pour matelas
Tejidos MILANO para colchoneta

JERRY

it / Vassoio in okumé con gambe pieghevoli, in legno di frassino. Ferramenta in acciaio inox AISI 316.

en / Tray in okumé, with folding legs in ash wood. Hardware in AISI 316 stainless steel.

fr / Plateau en okumé, avec pieds pliants en bois de frêne. Quincaillerie en acier inoxydable AISI 316.

es / Bandeja de okumé con patas plegables, en madera de fresno. Herrajes en acero inoxidable AISI 316.

6 POSIZIONI
6 POSITIONS

6 

 misure/ sizes



L 191 cm
P 61 cm
Hs 40 cm



pieghevole
folding
pliable
plegable



1 pz

L 165 cm
P 75 cm
H 9 cm
Kg 15



20 pz

L 170 cm
P 80 cm
H 180 cm
Kg 320



REGOLAZIONE SCHIENALE TRAMITE CORDELLA
BACKREST ADJUSTMENT BY ROPE
RÉGLAGE DU DOSSIER AVEC CORDON
AJUSTE DEL RESPALDO MEDIANTE SISTEMA DE CORDÓN



**OPZIONI / OPTIONS /
OPTIONNEL / OPTIONES:**

Cuscino/Cushion/Coussin/Cojín
50x25 cm, h 3 cm

Materassino/Mattress/Matelas/Colchoneta
h 3-5 cm

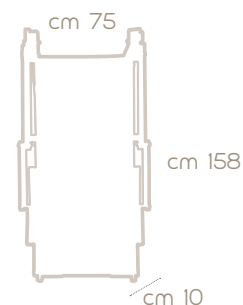

CHIUSO/CLOSED
FERMÉ/CERRADO

p. 127

Finiture in legno
Wood finishes
Finitions du bois
Acabados de madera

p. 132-133-135-136-138

Tessuti ROMAGNA, COR e RAM
ROMAGNA, COR and RAM canvases
Toiles ROMAGNA, COR et RAM
Tejidos ROMAGNA, COR y RAM

LETTINO LEGNO / WOODEN SUNBED TRANSAT EN BOIS / TUMBONA DE MADERA

- it / Lettino a 3 posizioni. Disponibile con o senza tettuccio parasole. Struttura in legno di frassino. Tessuto in pvc. 3 inclinazioni dello schienale. Con cordella. Ferramenta inox AISI 316.
- en / Sunbed 3 positions. pvc fabric. Available with or without sunshield. With structure in ash wood, with 3 inclinations of the backrest by cord. Hardware Inox AISI 316.
- fr / Transat 3 positions. Tissue en pvc. Disponible avec ou sans pare-soleil. Structure en bois de frêne. 3 inclinaisons de dossier avec cordon. Quincaillerie en acier inoxydable AISI 316.
- es / Tumbona de 3 posiciones. Tejido de pvc. Disponible con o sin parasol. Estructura de madera de fresno. Respaldo reclinable en 3 niveles diferentes. Sistema de cordón. Herrajes de acero inoxidable AISI 316.



3 POSIZIONI
3 POSITIONS

3 

 misure/ sizes



L 63,5 cm
P 113 cm
H 112,5 cm
Hs 36 cm



pieghevole
folding
pliable
plegable



1 pz

L 110 cm
P 64 cm
H 12,5 cm
Kg 8,2



40 pz

L 120 cm
P 120 cm
H 190 cm
Kg 340

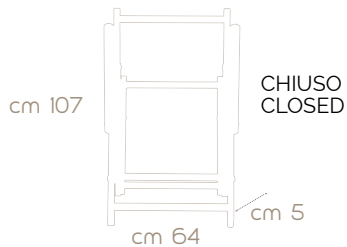

MARINELLA LEGNO WOODEN MARINELLA MARINELLA EN BOIS MARINELLA DE MADERA

p. 127

Finiture in legno
Wood finishes
Finitions du bois
Acabados de madera

p. 132-133-135-136-138

Tessuti ROMAGNA, COR e RAM
ROMAGNA, COR and RAM canvases
Toiles ROMAGNA, COR et RAM
Tejidos ROMAGNA, COR y RAM

it / Sdraio con braccioli in legno di frassino. Tessuto in pvc. Ferramenta inox AISI 316.

en / Deckchair with armrests with structure in ash wood, pvc fabric. Hardware Inox AISI 316.

fr / Chienne avec accoudoirs en bois de frêne. Tissue en pvc. Quincaillerie en acier inoxydable AISI 316.

es / Tumbona con reposabrazos de madera de fresno. Tejido de pvc. Herrajes de acero inoxidable AISI 316.



2 POSIZIONI
2 POSITIONS

2 

 misure/ sizes



L 47 cm
P 114 cm
H 108 cm
Hs 30 cm



pieghevole
folding
pliable
plegable



1 pz

L 140 cm
P 61 cm
H 4 cm
Kg 7



30 pz

L 140 cm
P 80 cm
H 135 cm
Kg 225

cm 61



cm 150

cm 5

CHIUSO/CLOSED
FERMÉ/CERRADO

 misure/ sizes



L 55 cm
P 120 cm
H 110 cm
Hs 30 cm



pieghevole
folding
pliable
plegable



1 pz

L 150 cm
P 78 cm
H 5 cm
Kg 8,8



30 pz

L 150 cm
P 80 cm
H 165 cm
Kg 225

cm 73



cm 150

cm 5

CHIUSO/CLOSED
FERMÉ/CERRADO



3 POSIZIONI
3 POSITIONS



4 POSIZIONI
4 POSITIONS

SDRAIO LEGNO

SENZA BRACCIOLI

WOOD DECKCHAIR WITHOUT ARMS

CHILIENNE EN BOIS SANS ACCOUDOIRS

TUMBONA DE MADERA SANS ACCOUDOIRS

SDRAIO LEGNO

CON BRACCIOLI

DECKCHAIR WITH ARMS

CHILIENNE AVEC ACCOUDOIRS

TUMBONA CON REPOSABRAZOS

p. 127

Finiture in legno
Wood finishes
Finitions du bois
Acabados de madera

p. 132-133-135-136-138

Tessuti ROMAGNA, COR e RAM
ROMAGNA, COR and RAM canvases
Toiles ROMAGNA, COR et RAM
Tejidos ROMAGNA, COR y RAM

54

it / Sdraio con braccioli o senza braccioli in legno di frassino. Tessuto in pvc. Ferramenta inox AISI 316.

en / Deckchair with armrests or without armrests, with structure in ash wood, pvc fabric. Hardware Inox AISI 316.

fr / Chlienne avec ou sans accoudoirs en bois de frêne. Tissue en pvc. Quincaillerie en acier inoxydable AISI 316.

es / Tumbona con reposabrazos o sin reposabrazos de madera maciza de fresno. Tejido de pvc. Herrajes de acero inoxidable AISI 316.

3/4 POSIZIONI
3/4 POSITIONS

3/4 







Ombrelloni
Parasols
Parasols
Sombrillas

Tipologia di copertura per gli ombrelloni

Cover versions for parasols

Type de couverture pour parasols

Tipo de cubierta de las sombrillas

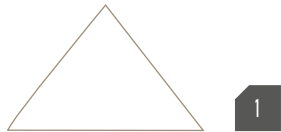

1

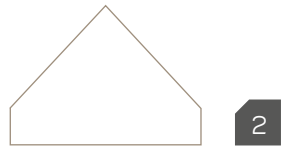

2

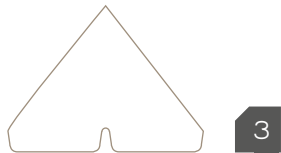

3

it / **Mantovana ombrelloni**

- 1 - senza mantovana
- 2 - una sola onda
- 3 - onde multiple

en / **Parasols valance**

- 1 - without valance
- 2 - with single wave valance
- 3 - Multiple wave

fr / **Cantonnère pour parasols**

- 1 - sans cantonnière
- 2 - avec une seule vague
- 3 - avec plusieurs vagues

es / **Sombrillas con volante**

- 1 - sin volante
- 2 - una onda
- 3 - múltiples ondas



it / Per zone esposte a vento di particolare intensità, gli ombrelloni possono essere richiesti con sfiatatoio.

en / For areas exposed to particularly intense wind, parasols can be supplied with the wind vent.

fr / Pour les zones exposées au vent d'une intensité particulière, les parasols peuvent être demandés avec l'évent.

es / Para las zonas expuestas a vientos especialmente fuertes, se pueden solicitar sombrillas con ventilación.



Confezione / Cover / Couverture / Cobertura

it / COPERTURA

Tessuto acrilico 100% tinto in pasta di massima robustezza. Il tessuto tinto in pasta offre UNA TENUTA DI COLORE ECCEZIONALE ANCHE DOPO UNA LUNGHISSIMA ESPOSIZIONE AL SOLE. Tutte le coperture vengono confezionate con le cuciture di unione degli spicchi di tipo ZIG-ZAG a quattro fili con apposito cucirino imputrescibile.

en / COVER

100% heavy duty paste-dyed acrylic fabric. The paste-dyed fabric offers EXCEPTIONAL COLOR RETENTION EVEN AFTER A VERY LONG EXPOSURE TO SUNLIGHT for the union of the segments, all the covers are sewn with four-thread zigzag stitching, with a special rot-proof sewing thread. Protective patch to avoid deterioration of the fabric is fixed with special nickel-plated brass eyelets

fr / COUVERTURE

Tissu 100% acrylique teint dans la masse de résistance maximale. Le tissu teint dans la masse offre une TENUE EXCEPTIONNELLE DE LA COULEUR MÊME APRÈS UNE TRÈS LONGUE EXPOSITION AU SOLEIL. Toutes les couvertures sont fabriquées avec les coutures de jonction de type ZIG-ZAG à quatre fils avec un coudre spécial imputrescible.

es / COBERTURA

Tejido 100 % acrílico teñido en pasta de máxima resistencia.

El tejido teñido en pasta ofrece UNA EXCEPCIONAL RESISTENCIA DEL COLOR INCLUSO TRAS UNA EXPOSICIÓN MUY PROLONGADA al sol.

Todas las cubiertas están fabricadas con costuras de unión de segmentos tipo ZIG-ZAG de cuatro hilos con hilo de coser especial resistente a la putrefacción.

VITE
SCREW
VIES
TORNILLO

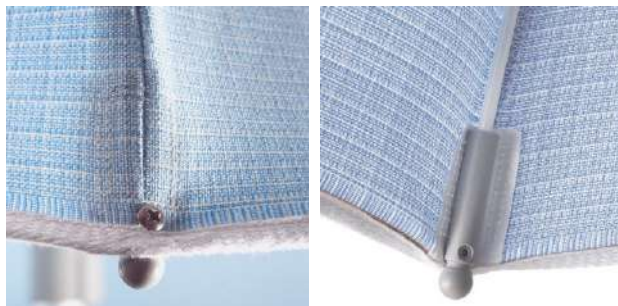

it / Nei nostri ombrelloni la copertura viene fissata ai terminali delle stecche con viti inox e con particolare rinforzo.

en / In our parasols, the cover is fixed to the ends of the ribs with stainless steel screws and with a particular reinforcement made by a nylon mold.

fr / Dans nos parasols, la couverture est fixée aux extrémités des baleines avec des vis en acier inoxydable et avec un renfort spécial.

es / En nuestros parasoles, la cubierta se fija a los extremos de los listones con tornillos de acero inoxidable y un refuerzo especial.

TASCA
POCKET
POCHE
BOLSILLO



it / A richiesta la copertura viene fissata con rinforzo a forma di tasca contenente i terminali delle stecche.

en / On request and as an alternative to the above, the cover is made with reinforced pockets in which the ends of the ribs are inserted.

fr / Sur demande, la couverture peut être fixée avec un renfort en forme de poche contenant les extrémités des baleines.

es / Bajo solicitud, la cubierta se fija con un refuerzo en forma de bolsillo que contiene los extremos de los listones.

RAGNI E STECCHE

FRAME AND RIBS

STRUCTURES ET BALEINES

ARAÑAS Y VARILLAS



n. 2



n. 3



n. 1



it / COLLANO (n.1), CORONA (n.2) E CAPPELOTTO (n.3)
IN SPECIALE MATERIALE NYLON ANTIUSURA.

- 8 STECCHE IN ACCIAIO Ø 5 MM
Misure: 90/8; 100/8; 110/8; 120/8; 130/8 cm
Extra-pesanti con doppie protezioni mediante zincatura e successiva plastificazione con ribattini di congiunzione ai forcelloni in acciaio inox
- SISTEMA DI AGGANCIAMENTO:
di tipo intercambiabile.

en / COLLAR (n.1), CROWN (n.2) AND CAP (n.3),
IN MOLDS MADE WITH SPECIAL WEAR-RESISTANT NYLON MATERIAL

- 8 STEEL RIBS Ø 5 MM
Measures: 90/8; 100/8; 110/8; 120; 130/8 cm
in extra heavy steel and with double protection by galvanizing and subsequent powder coating with stainless steel rivets at the points of connection to the swingarms
- FASTENING SYSTEM:
interchangeable type.

fr / COLLIER (n.1), COURONNE (n.2) ET CAPUCHON (n.3),
DANS DES MOULES EN NYLON SPÉCIAL RÉSISTANT À L'USURE

- 8 BALEINES EN ACIER Ø 5 MM
Mesures : 90/8; 100/8; 110/8; 120/8; 130/8 cm
Extra-Lourd avec double protections au moyen de galvanisation et plastification ultérieure avec de la poudre époxy, et avec les rivets pour assembler les bras oscillants en acier inoxydable
- SYSTÈME D'ACCROCHAGE :
de type interchangeable.

es / PIÑA CENTRAL (n.1), CORONA (n.2) Y TAPÓN (n.3)
DE MATERIAL ESPECIAL DE NYLON RESISTENTE AL DESGASTE.

- 8 VARILLAS DE ACERO Ø 5 MM
Medidas: 90/8; 100/8; 110/8; 120; 130/8 cm
Extrapesados con doble protección mediante galvanizado y posterior plastificación con remaches de unión a las horquillas de acero inoxidable
- SISTEMA DE ACOPLAMIENTO:
tipo intercambiable.

mod.
EGEO

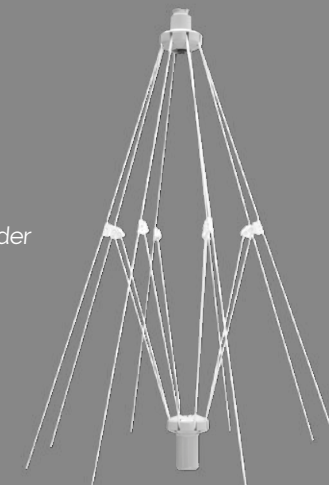

RAGNI E STECCHE FRAME AND RIBS STRUCTURES ET BALEINES ARAÑAS Y VARILLAS



n. 4



n. 2



n. 3



- it / n. 4
Toppa di protezione per evitare il deterioramento del tessuto. Fissate con particolari occhielli in ottone nichelato.
- en / Protective patch to avoid deterioration of the fabric is fixed with special nickel-plated brass eyelets.
- fr / Patches de protection pour éviter la détérioration du tissu. Fixés avec des œillets spéciaux en laiton nickelé.
- es / Parche protector para evitar el deterioro del tejido. Se sujeta con ojales especiales de latón niquelado.

- it / **COLLANO (n.1), CORONA (n.2) E CAPPELOTTO (n.3) IN SPECIALE MATERIALE DI NYLON ANTIUSURA CON PULSANTE DI SBLOCCO**
• **10 STECCHE IN ACCIAIO Ø 5 MM:**
Misure: 90/10; 100/10; 110/10; 120/10; 130/10 cm
Extra-pesanti con doppia protezione mediante zincatura e successiva plastificazione, con ribattini di congiunzione ai forcelloni in acciaio inox.

SISTEMA DI AGGANCIAMENTO: di tipo intercambiabile.
Attaccapanni ed innovativo sistema salvadito incorporati nel collano.

- en / **COLLAR (n.1), CROWN (n.2) AND CAP (n.3) IN SPECIAL WEAR-RESISTANT NYLON MATERIAL WITH RELEASE BUTTON**

• **10 RIBS IN STEEL Ø 5 MM:**
Sizes: 90/10; 100/10; 110/10; 120/10; 130/10 cm
In extra heavy steel and with double protection by galvanizing and subsequent powder coating with stainless steel rivets at the points of connection to the swingarms.

FASTENING SYSTEM: interchangeable type, with clothes hooks and innovative finger guard system incorporated in the collar.

- fr / **COLLIER (n.1), COURONNE (n.2) ET CAPUCHON (n.3) DANS DES MOULES EN NYLON SPÉCIAL RÉSISTANT À L'USURE, ET AVEC BOUTON DE DÉGAGEMENT**

• **10 BALEINES EN ACIER Ø 5 MM**
Mesures : 90/10; 100/10; 110/10; 120/10; 130/10 cm
Extra-Lourd avec double protections au moyen de galvanisation et plastification ultérieure avec de la poudre époxy, et avec les rivets pour assembler les bras oscillants en acier inoxydable.

SYSTÈME D'ACCROCHAGE : De type interchangeable.
Cintres et système innovant de protège-doigts incorporés dans le collier.

- es / **PIÑA CENTRAL (n.1), CORONA (n.2) Y TAPÓN (n.3) DE MATERIAL ESPECIAL DE NYLON RESISTENTE CON BOTÓN DE DESBLOQUEO**

• **10 VARILLAS DE ACERO Ø 5 MM:**
Medidas: 90/10; 100/10; 110/10; 120/10; 130/10 cm
Extrapesados con doble protección mediante galvanizado y posterior recubrimiento de plástico, con remaches que unen las horquillas de acero inoxidable.

SISTEMA DE ACOPLAMIENTO : tipo intercambiabile.
Ganchos para las toallas y un innovador sistema de protección de dedos en la piña central.

mod.
IONIO

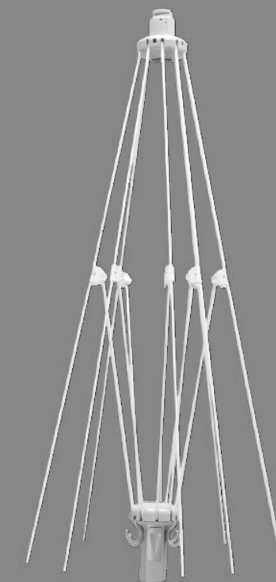

RAGNI E STECCHE FRAME AND RIBS STRUCTURES ET BALEINES ARAÑAS Y VARILLAS



MINI MAJESTIC MAJESTIC 2

Palo / Pole
Ø 40 mm

Baionetta

su richiesta: Eolo
on request: Eolo

BIG MAJESTIC

Palo / Pole
Ø 45 mm

Eolo

it / COLLANO, CORONA E CAPPELLOTTO IN SPECIALE MATERIALE DI NYLON ANTIUSURA CON PULSANTE DI SBLOCCO

• 8 STECCHE IN ACCIAIO Ø 5 MM: da 120 cm

Inserite in collano con sede specifica per creare uno spicchio intero ed uno mezzo.
Extra-pesanti con doppia protezione mediante zincatura e successiva plastificazione, con riki congiunzione ai forcelloni in acciaio inox.

en / COLLAR, CROWN AND CAP IN SPECIAL WEAR-RESISTANT PLASTIC WITH RELEASE BUTTON

• 8 STEEL RIBS Ø 5 MM: from cm 120

inserted into the collar in specific locations to create whole and half segments alternating between them, in extra heavy steel and with double protection by galvanizing and subsequent powder coating with stainless steel rivets at the points of connection to the swingarms.

fr / COLLIER, COURONNE ET CAPUCHON, DANS DES MOULES EN NYLON SPÉCIAL RÉSIDANT À L'USURE, ET AVEC BOUTON DE DÉGAGEMENT

• 8 BALEINES EN ACIER Ø 5 MM de 120 cm de long

insérées dans le collier avec des positions spécifiques pour créer un segment entier et un demi-segment.

Extra-Lourd avec double protections au moyen de galvanisation et plastification ultérieure avec de la poudre époxy, et avec les rivets pour assembler les bras oscillants en acier inoxydable

es / PIÑA CENTRAL, CORONA Y TAPÓN DE MATERIAL ESPECIAL DE NYLON RESISTENTE CON BOTÓN DE DESBLOQUEO.

• 8 VARILLAS DE ACERO Ø 5 MM: de 120 cm

Introducidas en la piña central con alojamiento específico para crear un segmento entero y uno y medio.

Extrapesados con doble protección mediante galvanizado y posterior recubrimiento de plástico, con remaches que unen las horquillas de acero inoxidable.

mod.
BALTICO



it / COLLANO, CORONA E CAPPELLOTTO IN SPECIALE MATERIALE DI NYLON ANTIUSURA CON PULSANTE DI SBLOCCO.

• 4 STECCHE o 8 STECCHE: in alluminio

Attaccapanni ed innovativo sistema salvadito incorporati nel collano.

en / COLLAR, CROWN AND CAP MADE WITH SPECIAL WEAR-RESISTANT NYLON MATERIAL, WITH RELEASE BUTTON

• 4 OR 8 RIBS: in aluminium

Clothes hooks and innovative finger guard system incorporated in the collar.

fr / COLLIER, COURONNE ET CAPUCHON, DANS DES MOULES EN NYLON SPÉCIAL RÉSIDANT À L'USURE, ET AVEC BOUTON DE DÉGAGEMENT

• 4 BALEINES OU 8 BALEINES: en n aluminium

Cintres et système innovant de protège-doigts incorporés dans le collier

es / PIÑA CENTRAL, CORONA Y TAPÓN DE MATERIAL ESPECIAL DE NYLON RESISTENTE CON BOTÓN DE DESBLOQUEO.

• 4 U 8 VARILLAS: de aluminio

Ganchos para las toallas y un innovador sistema de protección de dedos en la piña central.

mod.
MAJESTIC
MINI MAJESTIC
MAJESTIC 2
BIG MAJESTIC







TRADIZIONALE

it / SENZA MANTOVANA

- Tessuto acrilico: un tessuto per tutti i segmenti o due tessuti in tinta unita a spicchi alternati.
- Lunghezza stecche: 90; 100; 110; 120; 130 cm
- Bordino acrilico incluso, colore a scelta.
- Opzioni: Sfiatatoio.

en / WITHOUT VALANCE

- Fabric: Acrylic: one fabric for all the segments, or two fabrics in solid color with alternating segments.
- Ribs length: 90; 100; 110; 120; 130 cm
- Acrylic edge in one color of your choice included.
- Optional: Wind Vent

fr / SANS CANTONNIÈRE

- Tissu acrylique: un seul tissu pour tous les segments, ou deux tissus de couleur unie avec des segments alternés
- Longueur des baleines: 90; 100; 110; 120; 130 cm
- Bordure acrylique incluse, couleur au choix
- Optionnel: Évent.

es / SIN VOLANTE

- Tejido acrílico: un tejido para todos los segmentos o dos tejidos lisos en segmentos alternos.
- Longitud de la varilla: 90; 100; 110; 120; 130.
- Borde acrílico incluido, color a elegir.
- Opcional: Rejilla de ventilación.



TRADIZIONALE

it / CON MANTOVANA A UNA ONDA

- Tessuto acrilico: un tessuto per tutti i segmenti o due tessuti in tinta unita a spicchi alternati.
- Lunghezza stecche: 90; 100; 110; 120; 130 cm
- Opzioni: Sfiatatoio
- Opzionale: Bordino acrilico
- Opzioni: Mantovana onde multiple

en / WITH SINGLE WAVE VALANCE

- Fabric: Acrylic, one fabric for all the segments, or two fabrics in solid color with alternating segments
- Ribs length: 90; 100; 110; 120; 130 cm
- Optional: Wind Vent
- Optional: Acrylic edge in one color of your choice
- Optional: Multiple Waves

fr / AVEC CANTONNIÈRE UNE VAGUE

- Tissu acrylique: un seul tissu pour tous les segments, ou deux tissus de couleur unie avec des segments alternés
- Longueur des baleines: 90; 100; 110; 120; 130 cm
- Optionnel: Évent.
- Optionnel: Bordure acrylique, couleur au choix
- Optionnel: Cantonnière avec plusieurs vagues

es / CON VOLANTE DE UNA ONDA

- Tejido acrílico: un tejido para todos los segmentos o dos tejidos lisos en segmentos alternos.
- Longitud de la varilla: 90; 100; 110; 120; 130.
- Opcional: Rejilla de ventilación
- Opcional: Borde acrílico
- Opcional: Volante de ondas múltiples

RAGNO
FRAME
STRUCTURE
ARANA

mod.
EGEO
IONIO
p.60-61



1 pz

L 150 cm
P 20 cm
H 20 cm
Kg 9



72 pz

L 150 cm
P 120 cm
H 110 cm
Kg 590



it / SFIATATOIO

- Tessuti a tinta unita.
- Bordino acrilico incluso, colore a scelta.

en / WIND VENT

- Fabric: Acrylic, available only with fabrics in solid color
- Acrylic edge in one color of your choice included.

fr / ÉVENT

- Tissus de couleur unie.
- Bordure acrylique incluse, couleur au choix.

es / REJILLA DE VENTILACIÓN

- Tejidos de color liso.
- Borde acrílico incluido, color a elegir.





RAGNO
FRAME
STRUCTURE
ARANA

mod.
IONIO

p.61



1 pz

L 150 cm
P 25 cm
H 25 cm
Kg 9



55 pz

L 150 cm
P 120 cm
H 110 cm
Kg 465

PAGODINA

it / SENZA MANTOVANA

- Tessuto acrilico: un tessuto per tutti i segmenti o due tessuti in tinta unita a spicchi alternati.
- Lunghezza stecche: 100; 110; 120; 130 cm
- Bordino acrilico incluso, colore a scelta.
- Opzioni: Sfiatatoio.

en / WITHOUT VALANCE

- Fabric: Acrylic, one fabric for all the segments, or two plain colored fabrics and alternating segments
- Ribs length: 100; 110; 120; 130 cm
- Acrylic edge in one color of your choice included.
- Optional: Wind Vent.

fr / SANS CANTONNIÈRE

- Tissu acrylique : un seul tissu pour tous les segments, ou deux tissus de couleur unie avec des segments alternés
- Longueur des baleines : 100 ; 110 ; 120 ; 130 cm
- Bordure acrylique incluse, couleur au choix
- Optionnel: Événement.

es / SIN VOLANTE

- Tejido acrílico: un tejido para todos los segmentos o dos tejidos lisos en segmentos alternos.
- Longitud de la varilla: 100; 110; 120; 130
- Borde acrílico incluido, color a elegir.
- Opcional: Rejilla de ventilación.

PAGODINA

it / CON MANTOVANA A UNA ONDA

- Tessuto acrilico: un tessuto per tutti i segmenti o due tessuti in tinta unita a spicchi alternati.
- Lunghezza stecche: 100; 110; 120; 130 cm
- Bordino acrilico incluso.
- Opzioni: Mantovana onde multiple.

en / WITH SINGLE WAVE VALANCE

- Fabric: Acrylic, one fabric for all the segments, or two fabrics in solid color with alternating segments
- Ribs length : 100; 110; 120; 130 cm
- Acrylic edge in one color of your choice included.
- Optional : Wind Vent
- Optional : Multiple Waves

fr / AVEC CANTONNIÈRE UNE VAGUE

- Tissu acrylique : un seul tissu pour tous les segments, ou deux tissus de couleur unie avec des segments alternés
- Longueur des baleines : 100 ; 110 ; 120 ; 130 cm
- Bordure acrylique incluse, couleur au choix
- Optionnel: Événement.
- Optionnel: Cantonnière avec plusieurs vagues

es / CON VOLANTE DE UNA ONDA

- Tejido acrílico: un tejido para todos los segmentos o dos tejidos lisos en segmentos alternos.
- Longitud de la varilla: 100; 110; 120; 130
- Borde acrílico incluido.
- Opcional: Volante de ondas múltiples.



it / SFIATATOIO

- Tessuti a tinta unita.
- Bordino acrilico incluso, colore a scelta.

en / WIND VENT

- Fabric: Acrylic, available only with fabrics in solid color
- Acrylic edge in one color of your choice included.

fr / ÉVÉNEMENT

- Tissus de couleur unie.
- Bordure acrylique incluse, couleur au choix.

es / REJILLA DE VENTILACIÓN

- Tejidos de color liso.
- Borde acrílico incluido, color a elegir.





RAGNO
FRAME
STRUCTURE
ARANA

mod.
IONIO

p.61



1 pz

L 170 cm
P 25 cm
H 25 cm
Kg 9



55 pz

L 170 cm
P 120 cm
H 110 cm
Kg 465



PAGODA

it / SENZA MANTOVANA

- Tessuto acrilico: un tessuto per tutti i segmenti o due tessuti in tinta unita a spicchi alternati.
- Lunghezza stecche: 100; 110; 120; 130 cm
- Bordino acrilico incluso, colore a scelta.
- Opzioni: Sfiatatoio.

en / WITHOUT VALANCE

- Fabric: Acrylic, one fabric for all the segments, or two plain colored fabrics and alternating segments
- Ribs length: 100; 110; 120; 130 cm
- Acrylic edge in one color of your choice included.
- Optional: Wind Vent.

fr / SANS CANTONNIÈRE

- Tissu acrylique : un seul tissu pour tous les segments, ou deux tissus de couleur unie avec des segments alternés
- Longueur des baleines : 100 ; 110 ; 120 ; 130 cm
- Bordure acrylique incluse, couleur au choix
- Optionnel: Évén.

es / SIN VOLANTE

- Tejido acrílico: un tejido para todos los segmentos o dos tejidos lisos en segmentos alternos.
- Longitud de la varilla: 100; 110; 120; 130
- Borde acrílico incluido, color a elegir.
- Opcional: Rejilla de ventilación.

PAGODA

it / CON MANTOVANA A UNA ONDA

- Tessuto acrilico: un tessuto per tutti i segmenti o due tessuti in tinta unita a spicchi alternati.
- Lunghezza stecche: ; 100; 110; 120; 130 cm
- Bordino acrilico incluso, colore a scelta.
- Opzioni: Sfiatatoio, Mantovana onde multiple

en / WITH SINGLE WAVE VALANCE

- Fabric: Acrylic, one fabric for all the segments, or two plain colored fabrics and alternating segments
- Ribs length : 100; 110; 120; 130 cm
- Acrylic edge in one color of your choice included.
- Optional: Wind Vent, Multiple Waves

fr / AVEC CANTONNIÈRE UNE VAGUE

- Tissu acrylique : un seul tissu pour tous les segments, ou deux tissus de couleur unie avec des segments alternés
- Longueur des baleines : 100 ; 110 ; 120 ; 130 cm
- Bordure acrylique incluse, couleur au choix
- Optionnel: Évén, Cantonnière avec plusieurs vagues

es /

CON VOLANTE DE UNA ONDA

- Tejido acrílico: un tejido para todos los segmentos o dos tejidos lisos en segmentos alternos.
- Longitud de la varilla: ; 100; 110; 120; 130
- Borde acrílico incluido, color a elegir.
- Opcional: Rejilla de ventilación, Volante de ondas múltiples

it / SFIATATOIO

- Tessuti a tinta unita.
- Bordino acrilico incluso, colore a scelta.

en / WIND VENT

- Fabric: Acrylic, available only with fabrics in solid color
- Acrylic edge in one color of your choice included.

fr / ÉVÉNT

- Tissus de couleur unie.
- Bordure acrylique incluse, couleur au choix.

es / REJILLA DE VENTILACIÓN

- Tejidos de color liso.
- Borde acrílico incluido, color a elegir.

Senza sfiatatoio:

disponibile nella maggior parte delle tinte unite.
Without wind vent: available in most plain colours.

Sans événement:

disponibile dans la plupart des teintes unies.

Sin rejilla de ventilación:

disponible en la mayoría de los colores lisos.





RAGNO
FRAME
STRUCTURE
ARANA

mod.
IONIO

p.61



1 pz

L 150 cm
P 25 cm
H 25 cm
Kg 9



30 pz

L 150 cm
P 120 cm
H 110 cm
Kg 265



RAGNO
FRAME
STRUCTURE
ARANA

mod.
BALTICO

p.62



1 pz

L 150 cm
P 20 cm
H 20 cm
Kg 9



72 pz

L 150 cm
P 120 cm
H 110 cm
Kg 590

TUKUL

it / CON FRANGIA

- Tessuto acrilico totalmente ricoperto con rafia sintetica
- Si può avere nei colori: bianco, beige, rosso, blu, verde e aragosta
- Lunghezza stecche: 90; 100; 110 cm

en / WITH FRINGES

- Acrylic, fully covered with synthetic raffia with fringes
- Available in colours: white, beige, red, blue, green and orange
- Ribs length: 90; 100; 110 cm

fr / AVEC FRANGES

- Tissu acrylique entièrement recouvert de raphia synthétique
- Disponible en couleurs : blanc, beige, rouge, bleu, vert et homard
- Longueur des baleines : 90 ; 100 ; 110 cm

es / CON FLECOS

- Tejido acrílico totalmente recubierto de rafia sintética
- Disponible en los colores: blanco, beige, rojo, azul, verde y langosta
- Longitud de la varilla: 90/10; 100/10; 110/10

BALTICO

it / SENZA MANTOVANA

- Tessuto acrilico: un tessuto per tutti i segmenti o due tessuti in tinta unita a spicchi alternati.
- Misura: Ottagonale 190x190 cm
- Bordino acrilico incluso, colore a scelta.

en / WITHOUT VALANCE

- Fabric: Acrylic, one fabric for all the segments, or two fabrics in solid color with alternating segments
- Measure: Octagonal 190X190 cm
- Acrylic edge in one color of your choice included

fr / SANS CANTONNIÈRE

- Tissu acrylique : un seul tissu pour tous les segments, ou deux tissus de couleur unie avec des segments alternés
- Mesure : Octogonale 190x190 cm
- Bordure acrylique incluse, couleur au choix.

es / SIN VOLANTE

- Tejido acrílico: un tejido para todos los segmentos o dos tejidos lisos en segmentos alternos.
- Medidas: Octagonal 190x190
- Borde acrílico incluido, color a elegir.

 misure/ sizes



190x190 cm





RAGNO
FRAME
STRUCTURE
ARANA

mod.
MAJESTIC

p.62

 misure/ sizes



200x200 cm



1 pz

L 170 cm
P 25 cm
H 25 cm
Kg 10



45 pz

L 170 cm
P 120 cm
H 110 cm
Kg 455

MINI MAJESTIC

it / SENZA MANTOVANA

- Ragno: Majestic, versione con 4 stecche.
- Tessuto acrilico: un tessuto per tutti i segmenti o due tessuti in tinta unita a spicchi alternati.
- Bordino acrilico incluso, colore a scelta.
- **Opzioni: Sfiatatoio, Palo Ø 45 mm (Eolo)**

en / WITHOUT VALANCE

- Frame: Majestic, version with 4 aluminium ribs
- Fabric: Acrylic, one fabric for all the segments, or two fabrics in solid color with alternating segments.
- Acrylic edge in one color of your choice included.
- **Optional: Wind Vent, Pole Ø 45 mm (Eolo)**

fr / AVEC CANTONNIÈRE

- Structure: Majestic, version à 4 baleines.
- Tissu acrylique: un seul tissu pour tous les segments, ou deux tissus de couleur unie avec des segments alternés
- Bordure acrylique incluse, couleur au choix.
- **Optionnel: Événement, Mât Ø 45 mm (Eolo)**

es / SIN VOLANTE

- Araña: Majestic, versión de 4 varillas.
- Tejido acrílico: un tejido para todos los segmentos o dos tejidos lisos en segmentos alternos.
- Borde acrílico incluido, color a elegir.
- **Opcional: Rejilla de ventilación, Mástil Ø 45 mm (Eolo)**





MAJESTIC

- it / **CON MANTOVANA A ONDE MULTIPLE**
- Ragno: Majestic, versione con 8 stecche.
 - Tessuto acrilico: un tessuto per tutti i segmenti o due tessuti in tinta unita a spicchi alternati.
 - Sfiatatoio incluso.
 - Bordino acrilico incluso, colore a scelta.
 - **Opzioni: Palo Ø 45 mm (Eolo)**
- en / **WITH MULTIPLE WAVES VALANCE**
- Frame: Majestic, version with 8 aluminium ribs
 - Fabric: Acrylic, one fabric for all the segments, or two fabrics in solid color with alternating segments.
 - Wind Vent included
 - Acrylic edge in one color of your choice included
 - **Optional: Pole Ø 45 mm (Eolo)**
- fr / **AVEC CANTONNIÈRE PLUSIEURS VAGUES**
- Structure : Majestic, version à 8 baleines.
 - Tissu acrylique : un seul tissu pour tous les segments, ou deux tissus de couleur unie avec des segments alternés
 - Évén inclus
 - Bordure acrylique incluse, couleur au choix.
 - **Optionnel: Mât Ø 45 mm (Eolo)**
- es / **CON VOLANTE DE ONDAS MÚLTIPLES**
- Araña: Majestic, versión de 8 varillas.
 - Tejido acrílico: un tejido para todos los segmentos o dos tejidos lisos en segmentos alternos.
 - Incluye rejilla de ventilación.
 - Borde acrílico incluido, color a elegir.
 - **Opcional: Mástil Ø 45 mm (Eolo)**



MAJESTIC

- it / **SENZA MANTOVANA**
- Ragno: Majestic, versione con 8 stecche.
 - Tessuto acrilico: un tessuto per tutti i segmenti o due tessuti in tinta unita a spicchi alternati.
 - Sfiatatoio incluso.
 - Bordino acrilico incluso, colore a scelta.
 - **Opzioni: Palo Ø 45 mm (Eolo)**
- en / **WITHOUT VALANCE**
- Frame: Majestic, version with 8 aluminium ribs
 - Fabric: Acrylic, one fabric for all the segments, or two fabrics in solid color with alternating segments.
 - Wind Vent included
 - Acrylic edge in one color of your choice included.
 - **Optional: Pole Ø 45 mm (Eolo)**
- fr / **AVEC CANTONNIÈRE**
- Structure : Majestic, version à 8 baleines.
 - Tissu acrylique : un seul tissu pour tous les segments, ou deux tissus de couleur unie avec des segments alternés
 - Évén inclus
 - Bordure acrylique incluse, couleur au choix.
 - **Optionnel: Mât Ø 45 mm (Eolo)**
- es / **SIN VOLANTE**
- Araña: Majestic, versión de 8 varillas.
 - Tejido acrílico: un tejido para todos los segmentos o dos tejidos lisos en segmentos alternos.
 - Incluye rejilla de ventilación.
 - Borde acrílico incluido, color a elegir.
 - **Opcional: Mástil Ø 45 mm (Eolo)**

RAGNO
FRAME
STRUCTURE
ARANA

mod.
MAJESTIC

p.62

 misure/ sizes

 Ø 240 cm
Ø 280 cm

 200x200 cm

 1 pz
L 170 cm
P 25 cm
H 25 cm
Kg 10

 45 pz
L 170 cm
P 120 cm
H 110 cm
Kg 455





BIG MAJESTIC

it / SENZA MANTOVANA

- Ragno: Big Majestic, versione con 8 stecche.
- Tessuto acrilico: un tessuto per tutti i segmenti o due tessuti in tinta unita a spicchi alternati.
- Palo superiore Ø 45 mm con spessore maggiorato. Fermavento Eolo.
- Sfiatatoio incluso.
- Bordino acrilico incluso, colore a scelta.

en / WITHOUT VALANCE

- Frame: Big Majestic, version with 8 aluminium ribs
- Fabric: Acrylic, one fabric for all the segments, or two fabrics in solid color with alternating segments.
- Upper pole Ø 45 mm, with increased thickness. Version "Eolo" wind protection
- Wind Vent included
- Acrylic edge in one color of your choice included

fr / SANS CANTONNIÈRE

- Structure : Big Majestic, version à 8 baleines.
- Tissu acrylique : un seul tissu pour tous les segments, ou deux tissus de couleur unie avec des segments alternés
- Mât supérieur Ø 45 mm avec une épaisseur accrue. Avec coupe-vent Eolo.
- Évent inclus
- Bordure acrylique incluse, couleur au choix.

es/ SIN VOLANTE

- Araña: Big Majestic, versión con 8 varillas.
- Tejido acrílico: un tejido para todos los segmentos o dos tejidos lisos en segmentos alternos.
- Mástil superior de Ø 45 mm con mayor espesor. Con caperuza antiviento Eolo.
- Incluye rejilla de ventilación.
- Borde acrílico incluido, color a elegir.



 misure/ sizes

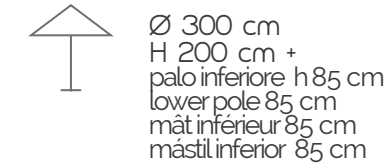
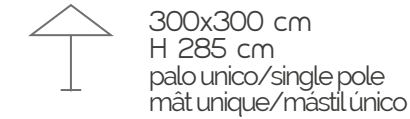

Ø 280 cm - 220 x 220 cm

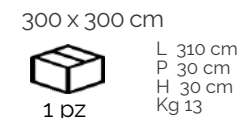
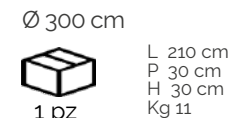

RAGNO
FRAME
STRUCTURE
ARANA

mod.
MAJESTIC

p.62

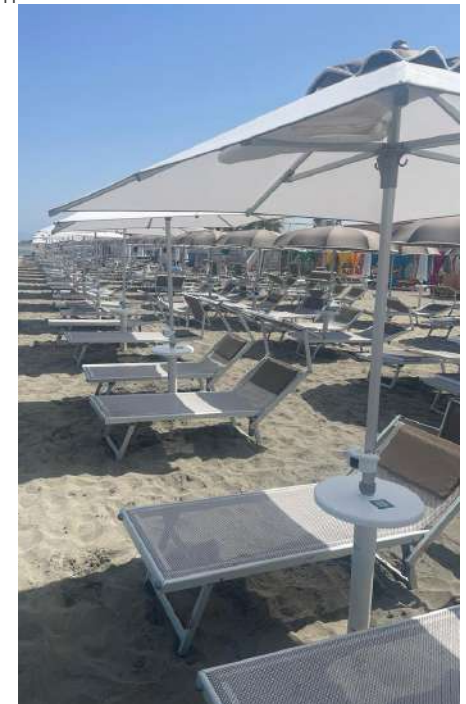



PALI DELL'OMBRELLONE PARASOL POLES MÂTS DE PARASOL MÁSTILES DE LA SOMBRILLA

it / Alluminio con anodizzazione anticorrosione.
Ø 40 mm

I pali standard non sono inclinabili. Solo su richiesta possono essere muniti di **snodo per inclinazione**.

I pali possono essere forniti nella **versione a Baionetta o Eolo**.

Baionetta lascia all'ombrellone la possibilità di ruotare e non danneggiare le stecche in caso di vento particolarmente insistente.

E' possibile aggiungere il Blocca Ombrellone (vedi pagina successiva).

Eolo fissa il palo superiore e inferiore tramite una vite.

en / Aluminum with anti-corrosion anodizing.
Ø 40 mm

Standard pole are not tiltable. On request they can be equipped with a **joint for the inclination** of the cover.

The poles can be supplied with the Bayonet or Eolo couplings.

The **Bayonet** coupling leaves to the parasol the possibility to rotate and not damage the ribs in the event of particularly strong wind.

It is possible to add the Parasol Lock (see next page).

The **Eolo** coupling fixes the upper and lower poles with a screw.

fr /

Aluminium avec anodisation anti-corrosion.
Ø 40mm

Les mâts en standard ne sont pas inclinables. Sur demande, ils peuvent être équipés d'un **joint d'inclinaison**.

Les mâts peuvent être fournis avec les accouplements à Baïonnette ou Eolo.

L'accouplement à **Baïonnette** laisse au parasol la possibilité de pivoter et de ne pas endommager les baleines en cas de vent particulièrement fort.

Il est possible d'ajouter le Bloque-Parasol (voir page suivante).

es / L'accouplement **Eolo** fixe les pôles supérieur et inférieur avec une vis.

Aluminio con anodizado anticorrosión.
Ø 40 mm

Los mástiles estándar no son inclinables. Bajo solicitud pueden equiparse con una articulación basculante.

Los mástiles se pueden suministrar en la versión de **Bayoneta o Eolo**.

Bayoneta: permite que el parasol pueda girar y no daña las varillas en caso de viento particularmente insistente.

Se puede añadir el bloqueador del parasol (véase la página siguiente).

Eolo: fija el mástil superior e inferior mediante un tornillo.

BAIONETTA

PALO
SUPERIORE

UPPER POLE

MÂT
SUPÉRIEUR

MÁSTIL
SUPERIOR



EOLO

PALO
SUPERIORE

UPPER POLE

COUPE-VENT
EOLO

MÂSTIL
SUPERIOR

BAIONETTA

PALO
INFERIORE

LOWER POLE

MÂT
INFÉRIEUR

MÁSTIL
INFERIOR



LISCIO PER EOLO

PALO
INFERIORE

LOWER POLE

MÂT
INFÉRIEUR

MÁSTIL
INFERIOR

MISURA DEL PALO INFERIORE: DA 80 CM A 120 CM
LOWER POLE LENGTH : FROM 80 CM TO 120 CM
LONGUEUR DU MÂT INFÉRIEUR : DE 80 CM À 120 CM
TAMAÑO DEL MÁSTIL INFERIOR: DE 80 CM A 120 CM

REGGI OMBRELLONE CON TAVOLINETTO PARASOL HOLDER WITH TABLE PORTE-PARASOL AVEC TABLE SOPORTE DE SOMBRILLA CON MESA PEQUEÑA

it / COMPOSTO DA TRE PARTI:

Tavolino rotondo Ø 40 cm in moplen (colori: beige, arancio, giallo, verde, blu, bianco), colonna disponibile solo nel colore bianco. Giunto per l'aggancio del palo superiore dell'ombrellone. La colonna va parzialmente inserita nella sabbia e una volta unita al giunto, sostituisce il palo inferiore dell'ombrellone.

en / COMPOSED OF THREE PARTS::

Round table Ø 40 cm in moplen (available in beige, orange, yellow, green, blue, white), column available only in white color, and Joint for the coupling of the upper pole of the parasol. The Column has to be partially inserted in the sand, and once joined to the Joint it replaces the lower pole of the parasol

fr / COMPOSÉ DE TROIS PARTIES :

Table ronde Ø 40 cm en moplen (disponible dans les couleurs : beige, orange, jaune, vert, bleu, blanc), colonne disponible uniquement en blanc, et joint pour la fixation du mât supérieur du parasol. La colonne doit être partiellement insérée dans le sable et une fois jointe au joint, elle remplace le mât inférieur du parasol.

es / CONSTA DE TRES PARTES:

Mesa auxiliar redonda Ø 40 cm en abs (colores: beige, naranja, amarillo, verde, azul y blanco), columna solo disponible en blanco. Junta para enganchar el mástil superior de la sombrilla. La columna se introduce parcialmente en la arena y, una vez unida a la junta, sustituye el mástil inferior de la sombrilla.

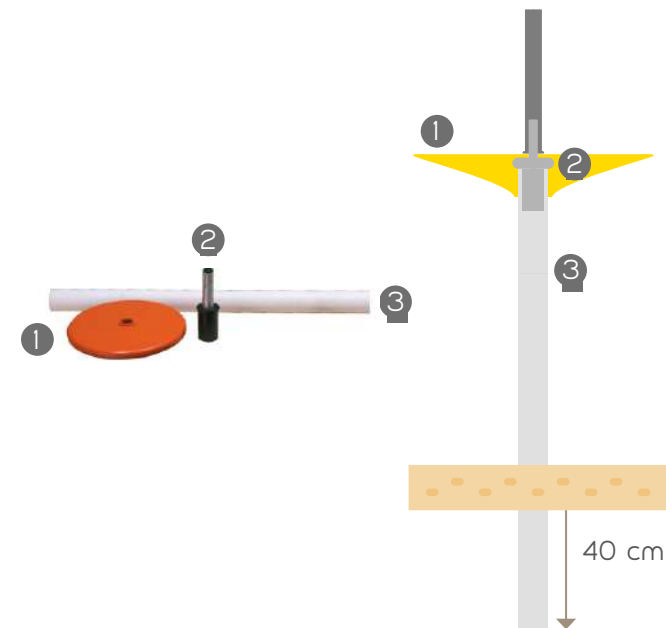

BLOCCA OMBRELLONE PARASOL LOCK BLOQUE-PARASOL BLOQUEADOR DE SOMBRILLAS

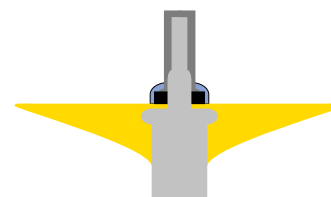

it / Disponibile per tutte le tipologie di palo dei nostri ombrelloni, fatta eccezione per i pali con innesto Eolo. E' composto da n°3 stampi in materiale plastico di alta qualità e 2 grani in acciaio inox. Lascia all'ombrellone la possibilità di ruotare. Facilissimo l'assemblaggio anche su ombrelloni usati.

en / Available for all our kind of poles for our parasols, with the exception of the Eolo coupling. It is composed by 3 elements in plastic molds of high quality, and by 2 stainless steel screws. It leaves the parasol the possibility to rotate. It is very easy to assemble, even on parasols used already.

fr / Disponible pour tous les types de mâts de nos parasols, à l'exception des mâts avec accouplement Eolo. Il est composé de 3 moules en matière plastique de haute qualité et de 2 vis en acier inoxydable. Il laisse au parasol la possibilité de pivoter. Très facile à monter même sur des parapluies usagés.

es / Disponible para todos los tipos de mástiles de nuestras sombrillas con acoplamiento antiviento Eolo. Consta de tres moldes de plástico de alta calidad y dos granos de acero inoxidable. Permite que la sombrilla gire. Fácil montaje incluso en sombrillas usadas.

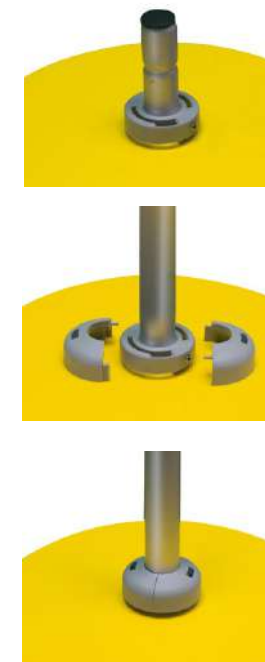



ACCESSORI PER OMBRELLONI / ACCESSORIES FOR UMBRELLAS ACCESSOIRES POUR PARASOLS / ACCESORIOS PARA SOMBRILLAS

Tavolinetto in moplen
per colonna
Table for column in moplen
Table en moplen pour
colonne
Mesa de moplen para
columna



Ø 40 cm





	L 43 cm P 43 cm H 10 cm Kg 1		L 43 cm P 43 cm H 87 cm Kg 10
1 pz		10 pz	

Tavolinetto in abs per palo
Table for pole in abs
Table en abs pour mât
Mesa en abs para mástil



Ø 40 cm





	L 42 cm P 42 cm H 9 cm Kg 1		L 53 cm P 42 cm H 42 cm Kg 8
1 pz		10 pz	

Tavolinetto in legno per
colonna e palo
Table for column and
pole in wood
Table en bois pour
colonne et mât
Mesa de madera para
columna y mástil



50x50 cm

	L 52 cm P 52 cm H 6 cm Kg 3		L 120 cm P 120 cm H 110 cm Kg 175
1 pz		50 pz	

Copri ombrelloni
Materiale: rafia sintetica
Parasol covers
Material: synthetic raffia
Housses pour parasols
Matière : raphia synthétique
Fundas para sombrillas
Material: rafia sintética



Numeratore per colonna
Column numbers
Numérateur par colonne
Numerador por columna



Numeratore per palo
Pole numbers
Numérateur pour mât
Numerador por mástil





Posacenere
Ashtrays
Cendrier
Ceniceros



	L 60 cm P 40 cm H 60 cm Kg 16
100 pz	

Colonna 120 cm
Column 120 cm
Colonne 120 cm
Columna 120 cm



	L 12 cm P 12 cm H 125 cm Kg 3		L 120 cm P 110 cm H 165 cm Kg 520
1 pz		250 pz	

ACCESSORI PER OMBRELLONI / ACCESSORIES FOR UMBRELLAS ACCESSOIRES POUR PARASOLS / ACCESORIOS PARA SOMBRILLAS

- it / BASI PORTA OMBRELLONE in polipropilene riempite con cemento, complete di tubo per l'innesto del palo dell'ombrellone.
 en / PARASOL HOLDER BASES in polypropylene filled with cement, complete with tube for grafting the parasol pole.
 fr / BASES PORTE-PARASOLS en polypropylène remplie de béton, et incluant le manchon pour mât.
 es / BASES PORTASOMBRILLAS de polipropileno rellenas de cemento, con tubo para fijar el mástil de la sombrilla.



- it / Per Big Majestic 300x300cm bisogna considerare il tubo con Ø 50 mm.
 en / For Big Majestic 300x300cm, the tube with a 50 mm diameter must be considered.
 fr / Pour Big Majestic 300x300cm, il faut considérer le manchon de Ø 50mm.
 es / Para Big Majestic 300x300cm hay que considerar el tubo de 50 cm de diámetro.



SIGILLO

- it / TAVOLINO COPRIBASE IN LEGNO
Struttura interna in alluminio.
 en / WOODEN TABLE BASE COVER
Internal structure in aluminium.
 fr / TABLE COUVRE-BASE EN BOIS
Structure interne en aluminium.
 es / MESITA / TAPA BASE DE MADERA
Estructura interna de aluminio.





 misure/ sizes



500x400 cm
500x500 cm
600x500 cm
600x600 cm



1 pz

L 450 cm
P 40 cm
H 40 cm
Kg 110

PIAZZA

- it / Ombrellone gigante con sistema telescopico a doppio ragno che ne consente la chiusura sopra sedie e tavoli sottostanti, senza il bisogno di spostarli. Struttura in alluminio verniciato e acciaio inox. Sfiatatoio incluso.
- en / Giant parasol. with double frame telescopic system that allows it to be closed over chairs and tables below without having to move them. It is manufactured with an aluminum powder coated and stainless steel structure. Wind vent included.
- fr / Parasol géant avec système télescopique à double structure qui permet de le fermer au-dessus des chaises et des tables en dessous, sans avoir besoin de les déplacer. Structure en aluminium peint avec des poudres époxy et en acier inoxydable. Évent inclus.
- es / Sombrilla gigante con sistema telescópico de doble araña que permite plegarla sobre las sillas y mesas inferiores sin necesidad de moverlas. Estructura de aluminio pintado y acero inoxidable. Incluye rejilla de ventilación.

PIAZZA



Gambone pieghevole in acciaio inox, con cerniera
Stainless steel tilting tube with hinge
Tube basculant avec fermeture éclair, en acier inoxydable
Pata plegable de acero inoxidable



1 pz

L 70 cm
P 22 cm
H 20 cm
Kg 10



Tessuto in acrilico 100%, gr. 320 m/q, trattato antimuffa, idrorepellente e resistente agli agenti atmosferici
Fabric 100% Acrylic, gr.320 m/q, anti-mold, water-repellent, and weather resistant treatments

Tissu 100% acrylique, gr. 320 m/q, traité anti-moisissure, hydrofuge et résistant aux intempéries

Tejido y borde 100 % acrílicos, 320 g/m2, con tratamiento antimoho, hidrófugo y resistente a la intemperie.



Corona e collano in acciaio inox
Stainless steel collar and crown
Couronne et collier en acier inoxydable
Corona y piña central de acero inoxidable



Tubo interno in acciaio inox
Stainless steel internal pole
Tube intérieur en acier inoxydable

Tubo interior de acero inoxidable



Base a vista in alluminio con piastre
Aluminium base at sight with plates
Base en aluminium à vue avec plaques
Base visible con placas



1 pz

L 110 cm
P 110 cm
H 30 cm
Kg 180



Giunto stecche

Joint ribs

Joint baleines

Unión varillas



Contropiastra da cementare
Counterplate to be cemented
Contreplaque à cimenter
Contraplaca que se debe cementar



1 pz

L 20 cm
P 20 cm
H 5 cm
Kg 15

TELESCOPICO
TELESCOPIC
TÉLESCOPIQUE
TELESCÓPICO

TELAIO:
FRAME:
STRUCTURE:
ESTRUCTURA:



BIANCO
WHITE
BLANC
BLANCO



ANTRACITE
ANTHRACITE
ANTHRACITE
ANTRACITA





ARTEMIDE

 misure/ sizes

 200x300 cm
300x300 cm
300x400 cm
400x400 cm

 Ø 300 cm
Ø 350 cm

 1 pz
L cm
P cm
H cm
Kg

it / Ombrellone gigante con struttura in legno, stecche 18x36 mm, palo da Ø 48 mm a Ø 60 mm a seconda della dimensione della copertura. Dotato di due carrucole zincate color oro e corda da mm 5 in poliestere. Fascetta color oro sulla canola. Ad ogni stecca viene applicato un particolare in nylon che facilita l'apertura dell'intero fusto. Sfiatatoio incluso. Colore: Naturale, Noce.

en / Giant umbrella with wooden structure, 18x36 mm ribs, and pole from D48 mm to D60 mm depending on the size of the cover. Equipped with two gold color galvanized pulleys and 5 mm polyester rope. Gold colored band on the collar. A nylon detail is applied to each rib which facilitates the opening of the entire structure. Wind vent included. Structure available in colours : Natural, Walnut.

fr / Parasol géant avec structure, baleines 18x36 mm, et mât en bois de D48 mm à D60 mm selon la dimension de la couverture. Equipé de deux poulies galvanisées couleur or et d'une corde en polyester de 5 mm. Bande dorée sur le collier. Un détail en nylon est appliqué sur chaque baleine qui facilite l'ouverture de l'ensemble de la structure. Évén inclus. Structure disponible dans les coloris : Naturel, Noyer.

es / Sombrilla gigante con listones 18x36 mm, poste Ø 60 mm en 200x300 cm, y poste 48 mm en Ø 300 cm. Estructura de madera de fresno, Kotò o Toulipie. Equipado con dos poleas galvanizadas color dorado y cuerda de 5 mm de poliéster. Banda de oro en la canola. A cada férula se aplica un detalle de nylon que facilita la apertura de todo el tallo. Respiradero incluido. Color: Natural, Nogal.

ACCESSORI / ACCESSORIES ACCESSOIRES / ACCESORIOS

ATTREZZATURA IN ACCIAIO INOX
EQUIPMENT IN STAINLESS STEEL
ÉQUIPEMENT EN ACIER INOXYDABLE
ELEMENTOS DE ACERO INOXIDABLE

it / 1 - Carrello portalettini;
2 - Trivella per palo ombrellone;
3 - Trivella per colonna;
4 - Manico inox;
5 - Vallo;
6 - Rastrello senza rete;
7 - Rastrello con rete;
8 - Retino.

en / 1 - Trolley for sunbeds;
2 - Auger for parasol lower poles;
3 - Auger for parasol lower column;
4 - Handle for rake or sand sieve;
5 - Sand sieve;
6 - Rake without net;
7 - Rake with net;
8 - Net.

fr / 1 - Chariot porte-transat;
2 - Tarière pour mât de parasol;
3 - Tarière pour colonne;
4 - Poignée en acier inoxydable;
5 - Tamis à sable;
6 - Râteau sans filet;
7 - Râteau avec filet;
8 - Filet.

es / 1 - Carro portabumbonas;
2 - Piqueta para mástil de la sombrilla;
3 - Piqueta para columna;
4 - Asa de acero inoxidable;
5 - Tamiz para arena;
6 - Rastrillo sin red;
7 - Rastrillo con red;
8 - Red.



TRIVELLA PER SABBIA O TERRENO
AUGER FOR SAND OR GROUND
TARIÈRE POUR SABLE OU TERRE
PIQUETA PARA ARENA O TERRENO



it / Trivella per ancoraggio ombrellone su sabbia o terreno.

en / Auger for anchoring parasol on sand or ground.

fr / Tarière pour ancrer le parasol sur le sable ou sur la terre.

es / Piqueta para anclar una sombrilla en la arena o en el terreno.

 L 55 cm
P 15 cm
H 15 cm
Kg 0,5
1 pz

 L 42 cm
P 60 cm
H 40 cm
Kg 13
40 pz

 misure/ sizes



200x200 cm
H 226 cm
Kg ~ 100

ACCESSORI / ACCESSORIES / ACCESOIRES / ACCESORIOS:

Tende nei colori: bianco, beige.
Curtains in the colors: white, beige.
Rideaux en couleurs : blanc, beige.
Cortinas en colores: blanco, beige.

n.4 Piastre in acciaio inox
per fissaggio a terra.

n.4 Stainless steel plates
for fixing to the ground.

n.4 Plaques en acier inoxydable pour la
fixation au sol.

n.4 Placas de acero inoxidable
para fijación al suelo.

JOY

n.1 Materassino filtrante tessuto Milano
200x200 cm diviso in due parti.
Spessore 10 cm

n.1 Filtering mattress with Milano canvas
200x200 cm divided into two parts.
Thickness 10 cm.

n.1 Matelas filtrants en toile Milano
200x200 cm divisé en deux parties.
Épaisseur 10 cm.

n.1 Colchoneta filtrantes de tela Milano,
200x200 cm dividido en dos partes.
Espesor 10cm.

DREAM

n.2 Materassini filtranti tessuto Milano, cad.
195x80 cm, spessore 10 cm
n.2 Cuscini filtranti tra i lettini tessuto Milano,
spessore 10 cm

n.2 Filtering mattresses with Milano canvas,
each 195x80 cm, thickness 10 cm
n.2 Filtering cushions between the sunbeds,
with Milano canvas, thickness 10 cm

n.2 Matelas filtrants en toile Milano, chacun
195x80 cm, épaisseur 10 cm
n.2 Coussins filtrants entre les transats, en
tissu Milano, épaisseur 10 cm

n.2 Colchonetas filtrantes de tela Milano,
cada una 195x80cm, espesor 10 cm
n.2 Cojines filtrantes entre las camas en tejido
Milano de 10 cm de espesor

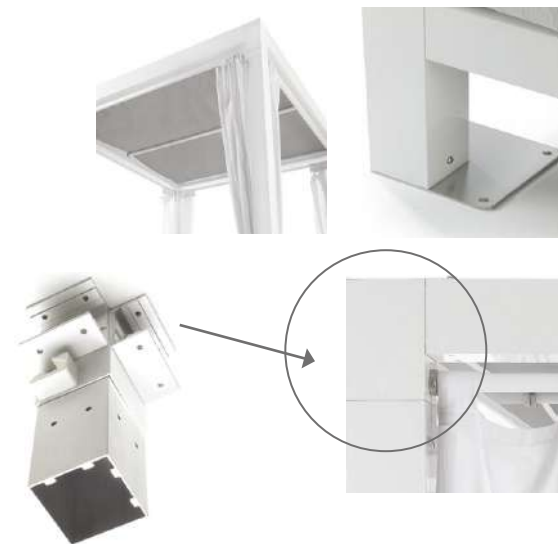

- it / Angolari aventi profilo con spessore maggiorato e filettato per una più efficace tenuta della vite.
- en / Corners with profile with increased thickness and threaded for a more effective holding of the screw.
- fr / Pièces d'angle avec profil à épaisseur augmentée et fileté pour un maintien plus efficace de la vis.
- es / Angulos con mayor grosor y perfil roscado para una sujeción más eficaz de los tornillos.

JOY / DREAM

- it / Struttura in alluminio verniciato bianco. Disponibile con schienale fisso (JOY) o reclinabile (DREAM). Copertura in tessuto Milano. Ombreggiante. Non impermeabile. Ferramenta in acciaio inox AISI 316.
- en / Aluminum structure powder coated in white color. Available with fixed (JOY) or reclining backrest (DREAM). Cover with Milano canvas. Shading. Not waterproof. Hardware in AISI 316 stainless steel.
- fr / Structure en aluminium de couleur blanche avec des poudres époxy. Disponible avec dossier fixe (JOY) ou inclinable (DREAM). Couverture en toile Milano. Ombrage. Non imperméable. Quincaillerie en acier inoxydable AISI 316.
- es / Estructura de aluminio pintado de blanco. Disponible con respaldo fijo (JOY) o reclinable (DREAM). Cubierta de tela de sombra Milano. No es impermeable. Herrajes en acero inoxidable AISI 316.





VERNICIATO - POWDER COATED
PEINT AVEC DES POUDRE EPOXY - PINTADO



RAL 9016
Bianco lucido
Gloss white
Blanc brillant
Blanco brillante

it / Tutti i colori RAL sono disponibili per quantitativi.
en / All RAL colours are available for quantities.
fr / Toutes les couleurs RAL sont disponibles pour les quantités.
es / Todos los colores RAL están disponibles para cantidades.

 misure/ sizes



200x200 cm
H 226 cm

ACCESSORI / ACCESSORIES / ACCESOIRES / ACCESORIOS:

Tende nei colori: bianco, beige.
Curtains in the colors: white, beige.
Rideaux en couleurs : blanc, beige.
Cortinas en colores: blanco, beige.

n.2 Materassini filtranti tessuto Milano,
cad. 195x80 cm, spessore 5 cm
n.2 Cuscini filtranti tra i lettini tessuto
Milano, spessore 5 cm

n.2 Filtering mattresses with Milano
canvas, each 195x80 cm, thickness
5 cm
n.2 Filtering cushions between the
sunbeds, with Milano canvas, thick-
ness 5 cm

n.2 Matelas filtrants en toile Milano,
chacun 195x80 cm, épaisseur 5 cm
n.2 Coussins filtrants entre les transats,
en toile Milano, épaisseur 5 cm

n.2 Esteras filtrantes de tela Milano,
cada una 195x80cm, espesor 5cm
n.2 Cojines filtrantes entre las camas
en tejido Milano de 5 cm de espesor



inox

n.4 Piastre in acciaio inox per fis-
saggio a terra
n.4 Stainless steel plates for fixing to
the ground
n.4 Plaques en acier inoxydable pour
la fixation au sol
n.4 Placas de acero inoxidable para
fijación al suelo



SUITE

it / Struttura in legno di abete lamellare. Completo di 2 lettini a doghe in legno di frassino, della misura 196,5x86,5 cm, con 6 inclinazioni dello schienale, regolabile con scaletta. Comprensivo di cassetti portaoggetti e appendiabiti. Copertura in tessuto RAM. Ombrggiante. Non impermeabile. Ferramenta in acciaio inox AISI 316.

en / Structure made of lamellar fir wood. Included 2 sunbeds with ashwood slats, measuring 196,5x86,5 cm, with 6 backrest inclinations, by ladder. Including storage drawers and coat hangers. Cover with RAM canvas. Shading, Not waterproof. Hardware in AISI 316 stainless steel.

fr / Structure en bois de sapin lamellé. Compris 2 transats à lattes en frêne, mesurant 196,5x86,5 cm, avec 6 inclinaisons de dossier, avec échelle. Y compris les tiroirs de rangement et les cintres. Couverture en toile RAM. Ombrage. Non imperméable. Quincaillerie en acier inoxydable AISI 316.

es / Estructura en madera de abeto laminada. Completo con 2 tumbonas con listones de madera de fresno de 196,5x86,5 cm cada una con 6 posiciones de respaldo, mediante escalera. Incluye cajones de almacenamiento y perchas. Cubierta de tela de sombra RAM. Sombreado. No es impermeable. Herrajes en acero inoxidable AISI 316.



JERRY

it / Vassoio in okumé con gambe pieghevoli, in legno di frassino. Ferramenta in acciaio inox AISI 316.

en / Tray in okumé, with folding legs in ash wood. Hardware in AISI 316 stainless steel.

fr / Plateau en okumé, avec pieds pliants en bois de frêne. Quincaillerie en acier inoxydable AISI 316.

es / Bandeja de okumé con patas plegables, en madera de fresno. Herrajes en acero inoxidable AISI 316.

6 POSIZIONI
6 POSITIONS

6 



p. 127

Finiture in legno
Wood Finishes
Finitions du bois
Acabados de madera

p. 138

Tessuti RAM
RAM canvas
Toile RAM
Tejidos RAM

Angolari in alluminio verniciato in tinta.
Corners in aluminum powder coated.
Pièces d'angle en aluminium peints
avec des poudres époxy.
Cantoneras en aluminio pintado del
mismo color.



 misure/ sizes



300x300 cm
H 226 cm
Kg ~ 80



1 pz

L 300 cm
P 80 cm
H 40 cm
Kg 105



5 pz

L 300 cm
P 80 cm
H 140 cm
Kg 450

Su richiesta può essere fornito con altre misure e con copertura fissa (non scorrevole).

On request it can be supplied with other sizes and with fixed cover (not sliding).

Sur demande, il peut être fourni avec d'autres mesures et avec une couverture fixe (non coulissant).

A petición se puede suministrar con otras medidas y con cubierta fija (no deslizante).



TESSUTO:
CANVAS:
TOILE:
TEJIDO:



RAM 107



RAM 102



GAZEBO IN ALLUMINIO

ALUMINIUM GAZEBO / PERGOLA EN ALUMINIUM / GAZEBO DE ALUMINIO

it / Struttura in alluminio. Copertura in tessuto RAM. Ombreggiante. Non impermeabile. Scorrimento della copertura da un lato all'altro, e di sgancio da entrambi i lati. Piastre in acciaio inox per fissaggio a terra. Ferramenta in acciaio inox AISI 316.

en / Aluminum structure, and cover with RAM canvas. Shading, Not waterproof. Sliding the cover from one side to the other, and release from both sides. Stainless steel plates for fixing to the ground. Bolts in Inox AISI 316

fr / Structure en aluminium. Couverture en toile RAM perforé d'ombrage non imperméable. Faire coulisser la couverture d'un côté à l'autre, et de le déverrouiller des deux côtés. Plaques en acier inoxydable pour fixation au sol. Quincaillerie en acier inoxydable AISI 316.

es / Estructura de aluminio. Cubierta de tela de sombra RAM. No es impermeable. Deslizar la cobertura de un lado a otro y de soltarla por ambos lados. Placas de acero inoxidable para la fijación al suelo. Herrajes de acero inoxidable AISI 316

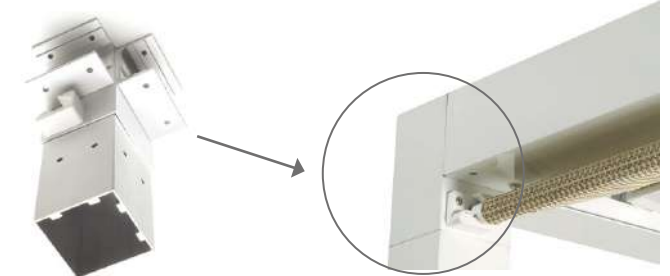

it / Angolari aventi profilo con spessore maggiorato e filettato per una più efficace tenuta della vite. Sistema di aggancio e sgancio rapido della copertura.

en / Corners with profile with increased thickness and threaded for a more effective holding of the screw. Quick coupling and release system.

fr / Pièces d'angle avec profil à épaisseur augmentée et fileté pour un maintien plus efficace de la vis. Système d'accrochage et décrochage rapide.

es / Ángulos con mayor grosor y perfil roscado para una sujeción más eficaz de los tornillos. Sistema de acoplamiento y desacoplamiento rápido.



VERNICIATO - POWDER COATED
PEINT AVEC DES POUDRE EPOXY - PINTADO



RAL 9016
Bianco lucido
Gloss white
Blanc brillant
Blanco brillante

it / Tutti i colori RAL sono disponibili per quantitativi.
en / All RAL colours are available for quantities.
fr / Toutes les couleurs RAL sont disponibles pour les quantités.
es / Todos los colores RAL están disponibles para cantidades.

 misure/ sizes



250x250 cm
300x300 cm
H 226 cm



1 pz

L 280 cm
P 50 cm
H 50 cm
Kg 90



3 pz

L 280 cm
P 80 cm
H 160 cm
Kg 290

Su richiesta può essere fornito con altre misure.

On request it can be supplied with other sizes.

Sur demande, il peut être fourni avec d'autres mesures.

A petición se puede suministrar con otras medidas.



TESSUTO:
CANVAS:
TOILE:
TEJIDO:



RAM 107



RAM 102

p. 127

Finiture in legno

Wood finishes

Finitions du bois

Acabados de madera

90

GAZEBO IN LEGNO

WOODEN GAZEBO / PERGOLA EN BOIS / GAZEBO DE MADERA

- it / Struttura in legno di abete lamellare. Copertura mediante tessuto RAM. Ombreggiante. Non impermeabile. Angolari in alluminio verniciato. Piastre in acciaio inox per fissaggio a terra. Ferramenta in acciaio inox AISI 316.
- en / Structure made lamellar fir wood. Cover with RAM canvas. Shading, Not waterproof. Powder coated aluminum corners. Stainless steel plates for fixing to the ground. Bolts in Inox AISI 316.
- fr / Structure en bois de sapin lamellé. Couverture en toile RAM. Non imperméable. Pièces d'angle en aluminium peintes. Plaques en acier inoxydable pour fixation au sol. Quincaillerie en acier inoxydable AISI 316.
- es / Estructura de madera laminada de abeto. Cubierta de tejido RAM. De sombra. No es impermeable. Esquinas de aluminio pintadas. Placas de acero inoxidable para la fijación al suelo. Herrajes de acero inoxidable AISI 316.



 misure/ sizes



APERTO/OPEN
L 235 cm P 166 cm
H 188 cm
CHIUSO/CLOSED
L 243 cm
H 234 cm



1 pz

L 240 cm
P 20 cm
H 10 cm
Kg 16,3



20 pz

L 250 cm
P 80 cm
H 120 cm
Kg 350



p. 139

Tessuti MILANO
MILANO canvases
Toiles MILANO
Tejidos MILANO

VERNICIATO
POWDER COATED
PEINT AVEC DES POUDRE ÉPOXY
PINTADO



RAL 9016
Bianco lucido
Gloss white
Blanc brillant
Blanco brillante

it / Tutti i colori RAL sono disponibili per quantitativi.

en / All RAL colours are available for quantities.

fr / Toutes les couleurs RAL sont disponibles pour les quantités.

es / Todos los colores RAL están disponibles para cantidades.

TENDOMBRA

it / Struttura in alluminio verniciato. Il tessuto è personalizzabile con nome, logo o disegni del cliente. Ferramenta inox AISI 316.

en / Structure in powder coated aluminum. The fabric can be customized with the customer's own name, logo, design. Hardware Inox AISI 316.

fr / Structure en aluminium peint en avec des poudres époxy. Le tissu peut être personnalisé avec le nom, le logo ou les dessins du client. Quincaillerie en acier inoxydable AISI 316.

es / Estructura de aluminio pintado. El tejido puede personalizarse con el nombre, el logotipo o el diseño del cliente. Herrajes de acero inoxidable AISI 316.



PEDANE OUTDOOR

OUTDOOR PLATFORMS

PLATES-FORMES POUR EXTÉRIEUR

PLATAFORMAS DE EXTERIOR

PEDANA IN POLIETILENE POLYETHYLENE PLATFORM PLATEFORME EN POLYETHYLENE PLATAFORMA DE POLIETILENO

cm 50x70
cm 50x100



1 pz

L 100 cm
P 50 cm
H 9 cm
Kg 6



10 pz

L 100 cm
P 60 cm
H 95 cm
Kg 65



PEDANA IN LEGNO WOODEN PLATFORM PLATEFORME EN BOIS PLATAFORMA DE MADERA

cm. 92,5 x 100 cm



1 pz

L 100 cm
P 93 cm
H 5 cm
Kg 18,2



30 pz

L 120 cm
P 100 cm
H 165 cm
Kg 560



it / Materiale: polietilene antiscivolo e stabilizzato ai raggi U.V.
Ogni pedana è corredata di appositi ganci che ne consentono l'unione sia dal lato lungo, sia da quello corto. E', perciò, possibile ottenere pavimentazioni di qualsiasi dimensione o passerelle larghe cm. 50 - 70 - 100 e con lunghezza a piacere.

en / Material: polyethylene non-slip, and UV resistant
Each platform is equipped with special hooks that allow them to be joined together both from the long side and from the short side. It is therefore possible to obtain floorings and walkways of any size with widths from 50-70-100 cm and length as desired.

fr / Matière : polyéthylène anti-dérapant et stabilisé aux UV
Chaque plate-forme est équipée de crochets spéciaux qui permettent de la joindre à la fois du côté long et du côté court. Il est donc possible d'obtenir des revêtements de sol de toutes dimensions, ou des passerelles d'une largeur de 50 ou 70 ou 100 cm et de la longueur au choix

es / Material: polietileno antideslizante y estabilizado a los rayos UV.
Cada baldosa está dotada de ganchos especiales que permiten unirla tanto por el lado largo como por el corto. Por lo tanto, es posible obtener suelos de cualquier tamaño o pasarelas de 50 - 70 - 100 cm de ancho y cualquier longitud.

it / Pedana modulare in legno montata su 3 binari in alluminio fissata con appositi rivetti. Giunti in nylon inclusi.
Moduli di dimensioni differenti a richiesta.
Possono essere impiegate per normali passerelle e come pavimentazione per gazebo, spazio giochi, lastricato per piscine e centri fitness.

en / Modular wooden platform, mounted on 3 aluminum rails and fixed with specific rivets. Nylon joints included.
On request, platforms of different sizes can be produced
It can be used to create walkways, as well as floorings for gazebos, children's play area, swimming pools, and fitness centers.

fr / Plate-forme modulaire en bois montée sur 3 rails en aluminium fixés avec des rivets spéciaux. Joints en nylon inclus.
Modules de dimensions différentes sur demande.
Ils peuvent être utilisés pour les passerelles et comme revêtement de sol pour les gazebos, les aires de jeux, les piscines et les centres de fitness.

es / Plataforma modular de madera montada sobre 3 railes de aluminio fijados con remaches. Incluye juntas de nylon. Módulos de diferentes tamaños bajo solicitud.
Se pueden utilizar para pasarelas normales y como pavimento para gazebos, parques infantiles, pavimentación de piscinas y gimnasios.

PEDANE OUTDOOR

OUTDOOR PLATFORMS
PLATESFORMES POUR EXTÉRIEUR
PLATAFORMAS DE EXTERIOR

**PEDANA IN ALLUMINIO, LEGNO
E TESSUTO**
ALUMINIUM, WOOD AND FABRIC
PLATFORM
PLATEFORME EN ALUMINIUM, BOIS
ET TISSU
PLATAFORMA DE ALUMINIUM,
MADERA Y TELA



cm. 100x100 cm h.6 cm

p. 128

Finiture in alluminio
Aluminium finishes
Finitions en aluminium
Acabados de aluminio

p. 139

Tessuti MILANO
MILANO canvases
Toiles MILANO
Tejidos MILANO



1 pz

L 102 cm
P 102 cm
H 8 cm
Kg 13



20 pz

L 120 cm
P 100 cm
H 128 cm
Kg 255

- it / Pedana composta da profilo in alluminio che contiene 2 pedane di legno ricoperte dal nostro tessuto in pvc, ottenendo così una pavimentazione rialzata dove è possibile nascondere e far passare cavi elettrici o connessioni varie sottostanti.
Consente un frequente cambio di look a costi bassissimi, con personalizzazione per eventi (compleanni, matrimoni, comunioni ecc).
- en / Platform composed by two wooden platforms covered with our pvc canvas, contained by a aluminum profile, thus obtaining a raised floor where it is possible to easily hide and pass electrical cables or various connections underneath.
It allows a frequent change of look at very low costs, as well as the possibility of customizing the fabric for events, such as birthdays, weddings, ceremonies, etc.
- fr / Plate-forme composée d'un profilé en aluminium qui contient 2 plates-formes en bois recouvertes de notre toile PVC, obtenant ainsi un plancher surélevé où il est possible de cacher et de faire passer des câbles électriques ou diverses connexions en dessous.
Il permet un changement de look fréquent à très faible coût, avec une personnalisation pour les événements (anniversaires, mariages, comunions, etc.).
- es / Plataforma formada por un perfil de aluminio que contiene 2 plataformas de madera cubiertas con nuestra tela de pvc, lo que da lugar a un suelo elevado en el que es posible ocultar y pasar los cables eléctricos o las distintas conexiones por debajo.
Permite un cambio de look frecuente a muy bajo coste, con personalización para eventos (cumpleaños, bodas, comuniones, etc.).

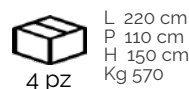
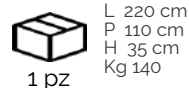
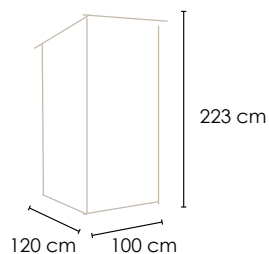
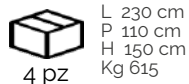
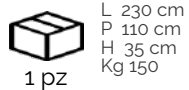
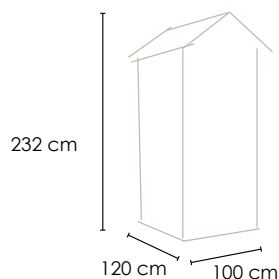



CABINE IN LEGNO GREZZO

RAW WOODEN CABINS / CABINES EN BOIS BRUT

CABINAS DE MADERA SIN TRATAR

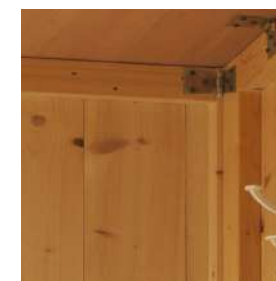
- it / Struttura autoportante con telaio in legno immaschiato ed incollato. L'assemblaggio è reso semplice dalla soluzione di cerniere in acciaio inox che vengono unite con apposito inserto. Le cabine sono fornite complete di pavimento, panca, mensola e attaccapanni. Essendo le cabine in legno grezzo, se utilizzate esternamente, il legno deve essere necessariamente impregnato e protetto, ed il tetto deve essere incatramato.
- en / Self-supporting structure with tapped and glued wooden frame
Easy to assemble, thanks to the stainless steel hinges that are joined with a special insert. The cabins are furnished complete with floor, seat bench, shelf, and hanger. Being the cabins in raw wood, if used externally the wood must necessarily be impregnated and protected, and the roof must be tarred.
- fr / Structure autoportante en bois taraudé et collé. L'assemblage est rendu simple par la solution de charnières en acier inoxydable qui sont reliées par un insert spécial. Les cabines sont livrées complètes avec plancher, banc, étagère et cintre. Les cabines étant en bois brut, si utilisées à l'extérieur, le bois doit obligatoirement être imprégné et protégé, et le toit doit être goudronné.
- es / Estructura autoportante con marco de madera moldeada y pegada. El montaje es fácil gracias a las bisagras de acero inoxidable que se unen con una inserción especial. Dado que las cabinas son de madera sin tratar, si se utilizan en el exterior, la madera debe estar necesariamente impregnada y protegida, y el techo debe estar alquitranado. Las cabinas se suministran completas con suelo, banco, balda y perchero.



A composite image featuring a woman in sunglasses smiling and holding a drink on the left, and a close-up of a table setting with a plate, knife, and fork on a dark wood-grain table on the right. The text is centered in the white diagonal area between them.

Sedute e Tavoli
Seats and Tables
Sièges et Tables
Asientos y mesas

 misure/ sizes



L 49 cm
P 55 cm
H 82 cm
Hs 46/47 cm



impilabile
stackable
empilable
apilable



1 pz

L 65 cm
P 60 cm
H 85 cm
Kg 8



10 pz

L 120 cm
P 80 cm
H 150 cm
Kg 100



VALENTINA

p. 128

Finiture in alluminio
Aluminium finishes
Finitions en aluminium
Acabados de aluminio

p. 139

Tessuti MILANO
MILANO canvases
Toiles MILANO
Tejidos MILANO

it / Sedia con struttura in alluminio verniciato. Seduta e schienale in tessuto pvc.
Ferramenta inox AISI 316.

en / Chair with structure in powder coated aluminium. Seat and back in pvc canvas.
Hardware Inox AISI 316.

fr / Chaise avec structure en aluminium peinte avec des poudres époxy.
Assise et dossier en toile pvc. Quincaillerie en acier inoxydable AISI 316.

es / Silla con estructura de aluminio pintado. Asiento y respaldo en tejidos pvc.
Herrajes de acero inoxidable AISI 316.



 misure/ sizes



L 57 cm
P 55 cm
H 82 cm
Hs 46/47 cm



impilabile
stackable
empilable
apilable



1 pz

L 65 cm
P 60 cm
H 85 cm
Kg 8



10 pz

L 120 cm
P 80 cm
H 150 cm
Kg 100



SAMANTHA

p. 128

Finiture in alluminio
Aluminium finishes
Finitions en aluminium
Acabados de aluminio

p. 139

Tessuti MILANO
MILANO canvases
Toiles MILANO
Tejidos MILANO

it / Sedia con braccioli. Struttura in alluminio verniciato. Seduta e schienale in tessuto pvc. Ferramenta inox AISI 316.

en / Chair with armrests. Structure in powder coated aluminium. Seat and back in pvc canvas. Hardware Inox AISI 316.

fr / Chaise avec accoudoirs. Structure en aluminium peinte avec des poudres époxy. Assise et dossier en toile pvc. Quincaillerie en acier inoxydable AISI 316.

es / Silla con reposabrazos. Estructura de aluminio pintado. Asiento y respaldo en tejido. Herrajes de acero inoxidable AISI 316.



 misure / sizes



L 56 cm
P 46 cm
H 90,5 cm
Hs 48 cm



pieghevole
folding
pliable
plegable



2 pz

L 55 cm
P 32 cm
H 95 cm
Kg 11



24 pz

L 125 cm
P 100 cm
H 185 cm
Kg 155



cm 90,5

CHIUSO/CLOSED
FERMÉ/CERRADO



REGISTA IN ALLUMINIO ALUMINIUM DIRECTOR'S CHAIR METTEUR EN SCÈNE EN ALUMINIUM SILLA DE DIRECTOR DE ALUMINIO

AURORA

p. 128

Finiture in alluminio
Aluminium finishes
Finitions en aluminium
Acabados de aluminio

p. 132-133-135-136-138-139

Tessuti ROMAGNA, COR, RAM e MILANO
ROMAGNA, COR, RAM and MILANO canvases
Toiless ROMAGNA, COR, RAM et MILANO
Tejidos ROMAGNA, COR, RAM y MILANO

it / Sedie con braccioli. Telaio in alluminio. Seduta e schienale in tessuto pvc. Ferramenta inox AISI 316.

en / Chairs with armrests. Aluminum frame. Seat and backrest with pvc canvas. Hardware Inox AISI 316.

fr / Chaises avec accoudoirs. Structure en aluminium. Assise et dossier en toile pvc. Quincaillerie en acier inoxydable AISI 316.

es / Sillas con reposabrazos. Estructura de aluminio. El asiento y el respaldo se suministran en tejido de pvc. Herrajes de acero inoxidable AISI 316.





 misure/ sizes



L 55 cm
P 52 cm
H 109 cm
Hs 67 cm



L 55 cm
P 52 cm
H 121 cm
Hs 78 cm



pieghevole
folding
pliable
plegable



pieghevole
folding
pliable
plegable



1 pz

L 110 cm
P 51 cm
H 24 cm
Kg 5,4



1 pz

L 110 cm
P 51 cm
H 24 cm
Kg 5,4



30 pz

L 120 cm
P 120 cm
H 200 cm
Kg 180



30 pz

L 120 cm
P 120 cm
H 200 cm
Kg 180



cm 109

CHIUSO/CLOSED
FERMÉ/CERRADO



cm 121

CHIUSO/CLOSED
FERMÉ/CERRADO



SGABELLO REGISTA DIRECTOR'S STOOL TABOURET METTEUR EN SCÈNE EN ALUMINIUM TABURETE DE DIRECTOR

p. 128

Finiture in alluminio
Aluminium finishes
Finitions en aluminium
Acabados de aluminio

p. 132-133-135-136-138-139

Tessuti ROMAGNA, COR, RAM e
MILANO
ROMAGNA, COR, RAM and MILANO
canvases
Toiles ROMAGNA, COR, RAM et
MILANO
Tejidos ROMAGNA, COR, RAM y
MILANO

- it / Sgabello con braccioli. Telaio in alluminio. Seduta e schienale in tessuto pvc. Ferramenta inox AISI 316.
- en / Stool with armrests. Aluminium frame. Seat and backrest with pvc canvas. Hardware Inox AISI 316.
- fr / Tabouret avec accoudoirs. Structure en aluminium. Assise et dossier en toile pvc. Quincaillerie en acier inoxydable AISI 316.
- es / Taburete con reposabrazos. Estructura de aluminio. El asiento y el respaldo en tejido de pvc. Herrajes de acero inoxidable AISI 316.

POGGIAPIEDI PER
LA VERSIONE ALTA
FOOTREST FOR
THE HIGH VERSION
REPOSE PIEDS POUR LA
VERSION HAUTE
REPOSAPIÉS PARA
LA VERSIÓN ALTA

 misure/ sizes



L 55 cm
P 52 cm
H 88 cm
Hs 48 cm



pieghevole
folding
pliable
plegable



2 pz

L 94 cm
P 33 cm
H 54 cm
Kg 13



28 pz

L 130 cm
P 100 cm
H 210 cm
Kg 210

CHIUSO/CLOSED
FERMÉ/CERRADO



cm 88



p. 127

Finiture in legno
Wood finishes
Finitions du bois
Acabados de madera

p. 132-133-135-136-138-139

Tessuti ROMAGNA, COR, RAM e MILANO
ROMAGNA, COR, RAM and MILANO
canvases
Toiles ROMAGNA, COR, RAM et MILANO
Tejidos ROMAGNA, COR, RAM y MILANO

REGISTA LEGNO

WOODEN DIRECTOR'S CHAIR

METTEUR EN SCÈNE EN BOIS

SILLA DE DIRECTOR DE MADERA

- it / Sedia Regista con struttura in legno di frassino. Seduta e schienale in tessuto pvc. Ferramenta inox AISI 316.
- en / Wooden Director's Chair with structure in ash wood. Seat and backrest with pvc canvas. Hardware Inox AISI 316.
- fr / Metteur en Scène en bois de frêne de haute qualité. Assise et dossier en toile pvc. Quincaillerie en acier inoxydable AISI 316.
- es / Silla de director con estructura de madera de fresno. El asiento y el respaldo en tejido de pvc. Herrajes de acero inoxidable AISI 316.





 misure/ sizes



L 55 cm
P 52 cm
H 121 cm
Hs 78 cm



pieghevole
folding
pliable
plegable



1 pz

L 110 cm
P 51 cm
H 24 cm



30 pz

L 120 cm
P 120 cm
H 200 cm



cm 121

CHIUSO/CLOSED
FERME/CERRADO



SGABELLO REGISTA IN LEGNO

WOODEN DIRECTOR'S STOOL
TABOURET METTEUR EN SCÈNE EN BOIS
TABURETE DE DIRECTOR DE MADERA

p. 127

Finiture in legno
Wood finishes
Finitions du bois
Acabados de madera

p. 132-133-135-136-138-139

Tessuti ROMAGNA, COR, RAM e MILANO
ROMAGNA, COR, RAM and MILANO canvases
Toiles ROMAGNA, COR, RAM et MILANO
Tejidos ROMAGNA, COR, RAM y MILANO

it / Sgabello Regista con struttura in legno di frassino. Seduta e schienale in tessuto pvc. Ferramenta inox AISI 316.

en / Wooden Director's stool with structure in ash wood. Seat and backrest with pvc canvas. Hardware Inox AISI 316.

fr / Metteur en Scène en bois de frêne. Assise et le dossier en toile pvc. Quincaillerie en acier inoxydable AISI 316.

es / Taburete con estructura de madera de fresno. El asiento y el respaldo en tejido de pvc. Herrajes de acero inoxidable AISI 316.



TELAI TAVOLO

TABLE FRAMES
STRUCTURE DES TABLES
ESTRUCTURAS MESA

 misure/ sizes



L/P 70-80-90
H 73 cm



impilabile
stackable
empilable
apilable



1 pz

L 90 cm
P 90 cm
H 90 cm
Kg 18



12 pz

L 130 cm
P 130 cm
H 180 cm
Kg 230

p. 128

Finiture in alluminio
Aluminium finishes
Finitions en aluminium
Acabados de aluminio

Per piano tavolo /For table tops/
Pour plateaux de table/ Para el
tablero de la mesa:

70x70 cm
80x80 cm
90x90 cm

Pag 111-112

Tipologie e finiture piani.
Table top types and finishes.
Types et finitions de plateaux.
Tipos y acabados superficies.

TAVERNA ALLUMINIO/ALUMINIUM/ALUMINIUM/ALUMINIO

it / Telaio tavolo in alluminio verniciato. Ferramenta inox AISI 316.

en / Table frame in powder coated aluminum. Hardware Inox AISI 316.

fr / Structure de table en aluminium peint avec des poudres époxy.
Quincaillerie en acier inoxydable AISI 316.

es / Estructura de mesa en aluminio pintado. Herrajes de acero inoxidable AISI 316.



TELAI TAVOLO

TABLE FRAMES
STRUCTURE DES TABLES
ESTRUCTURAS MESA

 misure/ sizes



L/P max 80
H 69 cm

smontato/dismounted
démonté/desmontado



1 pz

L 60 cm
P 65 cm
H 10 cm
Kg 3,2



20 pz

L 120 cm
P 80 cm
H 110 cm
Kg 90

p. 128

Finiture in alluminio
Aluminium finishes
Finitions en aluminium
Acabados de aluminio

Per piano tavolo /For table tops/
Pour plateaux de table/ Para el tablero
de la mesa:

max Ø 80 - 80x80 cm

Pag 111-112

Tipologie e finiture piani.
Table top types and finishes.
Types et finitions de plateaux.
Tipos y acabados superficies.



ELEGANT ALLUMINIO/ALUMINIUM/ALUMINIUM/ALUMINIO

it / Telaio tavolo in alluminio anodizzato o verniciato. Ferramenta inox AISI 316.

en / Table frames in anodized or powder coated aluminum. Hardware Inox AISI 316.

fr / Structure de table en aluminium anodisé ou peint avec des poudres époxy.
Quincaillerie en acier inoxydable AISI 316.

es / Estructura de la mesa en aluminio anodizado o pintado. Herrajes de acero inoxidable AISI 316.



FORNITI SMONTATI
SUPPLIED DISASSEMBLED
FOURNI DÉMONTÉ
SE SUMINISTRA DESMONTADO

TELAI TAVOLO

TABLE FRAMES
STRUCTURE DES TABLES
ESTRUCTURAS MESA

 misure/ sizes



L/P max 70
H 106 cm

smontato/dismounted
démonté/desmontado



1 pz

L 60 cm
P 95 cm
H 10 cm
Kg 3.5



20 pz

L 120 cm
P 80 cm
H 110 cm
Kg 96

p. 128

Finiture in alluminio
Aluminium finishes
Finitions en aluminium
Acabados de aluminio

Per piano tavolo /For table tops/
Pour plateaux de table/ Para el tablero
de la mesa:

max Ø 70 / 70x70 cm

Pag 111-112

Tipologie e finiture piani.
Table top types and finishes.
Types et finitions de plateaux.
Tipos y acabados superficies.



ELEGANT ALLUMINIO/ALUMINIUM/ALUMINIUM/ALUMINIO

- it / Telaio tavolo in alluminio anodizzato o verniciato. Ferramenta inox AISI 316.
- en / Table frames in anodized or powder coated aluminum. Hardware Inox AISI 316.
- fr / Structure de table en aluminium anodisé ou peint avec des poudres époxy.
Quincaillerie en acier inoxydable AISI 316.
- es / Estructura de la mesa en aluminio anodizado o pintado. Herrajes de acero inoxidable AISI 316.



FORNITI SMONTATI
SUPPLIED DISASSEMBLED
FOURNI DÉMONTÉ
SE SUMINISTRA DESMONTADO

TELAI TAVOLO

TABLE FRAMES
STRUCTURE DES TABLES
ESTRUCTURAS MESA

 misure/ sizes



L/P max 90
H 70,5 cm

smontato/dismounted
démonté/desmontado



1 pz

L 87 cm
P 65 cm
H 15 cm
Kg 6,8



20 pz

L 120 cm
P 80 cm
H 140 cm
Kg 150

p. 127

Finiture in legno
Wood finishes
Finitions du bois
Acabados de madera

Per piano tavolo /For table tops/
Pour plateaux de table/ Para el tablero
de la mesa:

max Ø 90 - 90x90 cm

Pag 111-112

Tipologie e finiture piani.
Table top types and finishes.
Types et finitions de plateaux.
Tipos y acabados superficies.



ELEGANT LEGNO/WOOD/BOIS/MADERA

it / Telaio tavolo con struttura in legno di frassino. Ferramenta inox AISI 316.

en / Table frame with structure in ash wood. Hardware Inox AISI 316.

fr / Structure de table en bois de frêne. Quincaillerie en acier inoxydable AISI 316.

es / Estructura de madera de fresno. Herrajes de acero inoxidable AISI 316.

FORNITI SMONTATI
SUPPLIED DISASSEMBLED
FOURNI DÉMONTÉ
SE SUMINISTRA DESMONTADO

TELAI TAVOLO

TABLE FRAMES
STRUCTURE DES TABLES
ESTRUCTURAS MESA

 misure/ sizes



L/P max 80 cm
H 72 cm

smontato/dismounted
démonté/desmontado



1 pz

L 55 cm
P 55 cm
H 75 cm
Kg 6,5



20 pz

p. 127

Finiture in legno
Wood finishes
Finitions du bois
Acabados de madera

Per piano tavolo /For table tops/
Pour plateaux de table/ Para el tablero
de la mesa:

max Ø 80 - 80x80 cm

Pag 111-112

Tipologie e finiture piani.
Table top types and finishes.
Types et finitions de plateaux.
Tipos y acabados superficies.



VINTAGE LEGNO/WOOD/BOIS/MADERA

- it / Telaio tavolo con struttura in legno di frassino. Ferramenta inox AISI 316.
- en / Table frame with structure in ash wood. Hardware Inox AISI 316.
- fr / Structure de table en bois de frêne. Quincaillerie en acier inoxydable AISI 316.
- es / Estructura de madera de fresno. Herrajes de acero inoxidable AISI 316.

FORNITI SMONTATI
SUPPLIED DISASSEMBLED
FOURNI DÉMONTÉ
SE SUMINISTRA DESMONTADO

TELAIO TAVOLO

TABLE FRAMES
STRUCTURE DES TABLES
ESTRUCTURAS MESA

 misure/ sizes

 L/P max 70
H 104 cm

smontato/dismounted
démonté/desmontado

 L 57,5 cm
P 57,5 cm
H 104 cm
Kg 8

 20 pz

p. 127

Finiture in legno
Wood finishes
Finitions du bois
Acabados de madera

Per piano tavolo /For table tops/
Pour plateaux de table/ Para el tablero
de la mesa:

max Ø 70 - 70x70 cm

Pag 111-112

Tipologie e finiture piani.
Table top types and finishes.
Types et finitions de plateaux.
Tipos y acabados superficies.

VINTAGE H LEGNO/WOOD/BOIS/MADERA

it / Telaio tavolo con struttura in legno di frassino. Ferramenta inox AISI 316.

en / Table frame with structure in ash wood. Hardware Inox AISI 316.

fr / Structure de table en bois de frêne. Quincaillerie en acier inoxydable AISI 316.

es / Estructura de madera de fresno. Herrajes de acero inoxidable AISI 316.



FORNITI SMONTATI
SUPPLIED DISASSEMBLED
FOURNI DÉMONTÉ
SE SUMINISTRA DESMONTADO

PIANI TAVOLO Stratificato HPL

TABLE TOPS
 PLATEAUX DE TABLE
 TABLEROS DE MESA

HPL Laminated
 HPL Stratifié
 HPL Estratificado

Ø59 - Ø69 - Ø79 - Ø89
 59x59 - 69x69 - 79x79 - 89x89 cm

it / Piani stratificati HPL. Bordo sottile o retto.
 Cuore nero per i laminati a tinta unita. Cuore marrone per i laminati effetto legno.

en / HPL laminated tops. Thin or straight edge.
 Black core for plain color laminates. Brown core for wood-effect laminates.

fr / Plateaux stratifiés HPL. Bord fin ou droit.
 Cœur noir pour les stratifiés de couleur unie. Cœur marron pour stratifiés effet bois.

es / Tableros laminados HPL. Borde fino o recto.
 Corazón negro para laminados de color liso. Corazón marrón para laminados efecto madera.



 L 90 cm
 P 90 cm
 H 4,5 cm
 Kg 12
 2 pz

 L 120 cm
 P 90 cm
 H 150 cm
 Kg 430
 70 pz

 1 cm
 Bordo sottile
 Thin edge
 Bord fin
 Borde fino

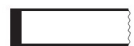
 1 cm
 Bordo retto
 Straight edge
 Bord droit
 Borde recto

ARPA



4543 ALEVÈ 4573 ALEVÈ 4575 LARIX 4587 ALEVÈ

Le immagini delle finiture sono indicative e possono subire variazioni cromatiche.
 The images of the finishes are indicative and may have chromatic variations.
 Les images des finitions sont à titre indicatif et peuvent subir des variations chromatiques.
 Las imágenes de los acabados son indicativas y pueden estar sujetas a variaciones de color.

PIANI TAVOLO

TABLE TOPS
PLATEAUX DE TABLE
TABLEROS DE MESA

Legno

Wood
Bois
Madera



1 pz

L 90 cm
P 90 cm
H 4,5 cm
Kg 12



35 pz

L 120 cm
P 90 cm
H 150 cm
Kg 430



60x60 - 70x70 - 80x080 - 90x90 cm

it / Piano in legno di frassino h 2,5 cm.

en / Wooden table top in ash wood h 2,5 cm.

fr / Plateau en bois de frêne h 2,5 cm.

es / Tablero de madera de fresno h 2,5 cm.



p. 118

Finiture in legno

Wood finishes

Finitions du bois

Acabados de madera

PIANI TAVOLO

TABLE TOPS
PLATEAUX DE TABLE
TABLEROS DE MESA

Alluminio

Aluminium
Aluminium
Aluminio



1 pz

L 90 cm
P 90 cm
H 4,5 cm
Kg 6



35 pz

L 120 cm
P 90 cm
H 150 cm
Kg 215



70x70 - 80x080 - 90x90 cm

it / Piano a doghe in alluminio.

en / Aluminum slats table top.

fr / Plateau à lattes en aluminium.

es / Tablero de listones de aluminio.



p. 116

Finiture in alluminio

Aluminium finishes

Finitions en aluminium

Acabados de aluminio

 misure/ sizes



LxP 80x80 cm
H 72 cm



pieghevole
folding
pliable
plegable



1 pz

L 104 cm
P 80 cm
H 6 cm
Kg 9.7



20 pz

L 120 cm
P 80 cm
H 135 cm
Kg 210



LxP 60x60 cm
H 46 cm



pieghevole
folding
pliable
plegable



1 pz

L 72 cm
P 60 cm
H 6 cm
Kg 6



40 pz

L 120 cm
P 80 cm
H 135 cm
Kg 255



LxP 70x42 cm
H 46 cm



pieghevole
folding
pliable
plegable



1 pz

L 55 cm
P 7 cm
H 6 cm
Kg 5



40 pz

L 120 cm
P 80 cm
H 135 cm
Kg 215

p. 128

Finiture in alluminio
Aluminium finishes
Finitions en aluminium
Acabados de aluminio

TAVOLI PIEGHEVOLI ALLUMINIO

FOLDING ALUMINIUM TABLES

TABLES PLIANTES EN ALUMINIUM

MESAS PLEGABLES DE ALUMINIO

it / Tavoli pieghevoli in alluminio con piano a doghe.
Ferramenta inox AISI 316.

en / Folding aluminium tables with slatted top.
Hardware Inox AISI 316.

fr / Tables pliantes en aluminium avec plateau à lattes.
Quincaillerie en acier inoxydable AISI 316.

es / Mesas plegables de aluminio con tablero de listones.
Herrajes de acero inoxidable AISI 316.



TAVOLINI BASSI IN ALLUMINIO

ALUMINIUM LOW TABLES

TABLES BASSES EN ALUMINIUM

MESAS BAJAS DE ALUMINIO

it / Tavoli in alluminio con piano a doghe. Ferramenta inox AISI 316.

en / Painted aluminium low tables with slatted top. Hardware Inox AISI 316.

fr / Tables en aluminium avec plateau à lattes. Quincaillerie en acier inoxydable AISI 316.

es / Mesas de aluminio con tablero de listones. Herrajes de acero inoxidable AISI 316.



 misure/ sizes



LxP 60x40 cm
H 37 cm



1 pz

L 40 cm
P 60 cm
H 37 cm
Kg 4.2



24 pz

L 120 cm
P 80 cm
H 150 cm
Kg 117



LxP 40x40 cm
H 37 cm



1 pz

L 40 cm
P 40 cm
H 37 cm
Kg 3.5



36 pz

L 120 cm
P 80 cm
H 150 cm
Kg 138

 misure/ sizes

 LxP 47x50 cm
H 51 cm

 L 53 cm
P 53 cm
H 55 cm
Kg 5.5
1 pz

p. 128

Finiture in alluminio
Aluminium finishes
Finitions en aluminium
Acabados de aluminio

 misure/ sizes

 LxP 50x50 cm
H 41 cm

 L 50 cm
P 50 cm
H 41 cm
Kg 6.8
1 pz

 L 130 cm
P 80 cm
H 165 cm
Kg 180
24 pz

p. 127

Finiture in legno
Wood finishes
Finitions du bois
Acabados de madera

CUBOTTO

- it / Tavolo in alluminio con piano a doghe.
Ferramenta inox AISI 316.
- en / Aluminium low table with slatted top.
Hardware Inox AISI 316.
- fr / Table en aluminium avec plateau à lattes.
Quincaillerie en acier inoxydable AISI 316.
- es / Mesa de aluminio con tablero de listones.
Herrajes de acero inoxidable AISI 316.



TAVOLINO BASSO IN LEGNO

LOW WOODEN TABLE
TABLES BASSE EN BOIS
MESA BAJA DE MADERA

- it / Tavolino basso in legno con piano a doghe e struttura in legno di frassino.
Ferramenta inox AISI 316.
- en / Low wooden table with slatted top,
with structure in ash wood.
Hardware Inox AISI 316.
- fr / Table basse en bois de frêne.
Quincaillerie en acier inoxydable AISI 316.
- es / Mesa baja de madera con tablero de listones y estructura de madera de fresno.
Herrajes de acero inoxidable AISI 316.



 misure / sizes

sgabello / stool
tabouret / taburete:

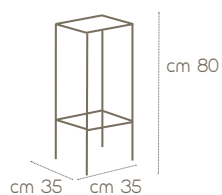

1 pz

L 35 cm
P 35 cm
H 82 cm
Kg 6



12 pz

L 120 cm
P 85 cm
H 160 cm
Kg 90

tavolo / table
table/mesa:

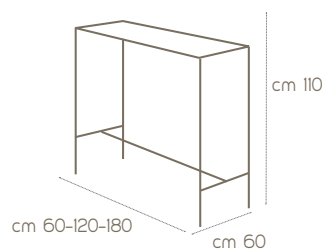

60x60x110 cm



1 pz

L 60 cm
P 60 cm
H 110 cm
Kg 10



6 pz

L 120 cm
P 110 cm
H 190 cm
Kg 75

120x60x110 cm



1 pz

L 120 cm
P 60 cm
H 110 cm
Kg 20



2 pz

L 120 cm
P 120 cm
H 125 cm
Kg 55

180x60x110 cm



1 pz

L 180 cm
P 60 cm
H 110 cm
Kg 30



2 pz

L 180 cm
P 120 cm
H 125 cm
Kg 75

HAPPY

it / Prodotti in alluminio e stratificato HPL oppure nella versione in legno di frassino ed okumè.
Ferramenta inox AISI 316.

en / Manufactured in aluminum and HPL laminate or ash wood and okumé version.
Hardware Inox AISI 316.

fr / Fabriqués en aluminium et HPL stratifié ou dans la version en bois frêne et bois d'okoumé.
Quincaillerie en acier inoxydable AISI 316.

es / Producida en aluminio y laminado HPL o en madera de fresno y okume.
Herrajes de acero inoxidable AISI 316.



p. 128
Finiture in alluminio
Aluminium finishes
Finitions en aluminium
Acabados de aluminio

p. 111
Finiture stratificato HPL
HPL laminated
Finitions HPL Stratifié
Acabados laminados HPL



p. 127
Finiture in legno
Wood finishes
Finitions du bois
Acabados de madera

 misure/ sizes



L 186 cm
P 157 cm
H 203 cm



L 186 cm
P 80 cm
H 75 cm

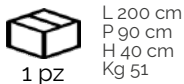

L 200 cm
P 90 cm
H 40 cm
Kg 51

VOLPINA

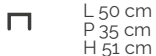

L 50 cm
P 35 cm
H 51 cm

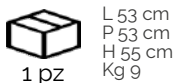

L 53 cm
P 53 cm
H 55 cm
Kg 9

GRADISCA



L 166 cm
P 35 cm
H 51 cm

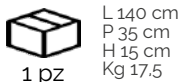

L 140 cm
P 35 cm
H 15 cm
Kg 17.5

FORNITI SMONTATI
SUPPLIED DISASSEMBLED
FOURNI DÉMONTÉ
SE SUMINISTRA DESMONTADO

p. 128

Finiture in alluminio
Aluminium finishes
Finitions en aluminium
Acabados de aluminio

p. 127

Finiture in legno
Wood finishes
Finitions du bois
Acabados de madera

p. 139

Tessuti MILANO
MILANO canvases
Toiles MILANO
Tejidos MILANO

116



AMARCORD

- it / Telaio in alluminio verniciato e piano a doghe in legno di frassino. Copertura in tessuto Milano. Ombreggiante. Non impermeabile. Ferramenta inox AISI 316.
- en / Table with structure in powder coated aluminum frame and ash wood slatted top. Cover with Milano fabric. Shading. Not waterproof. Hardware Inox AISI 316.
- fr / Structure en aluminium peint avec des poudre époxy et plateau en lattes en bois frêne et bois d'okoumè. Couverture en tissu Milano. Ombrage. Non imperméable. Quincaillerie en acier inoxydable AISI 316.
- es / Estructura de aluminio pintado y tablero de listones de madera de fresno. Cubierta de tela de sombra Milano. No es impermeable. Herrajes de acero inoxidable AISI 316.



VOLPINA

PANCA/BENCH/BANC/BANCO



GRADISCA

PANCA/BENCH/BANC/BANCO





 misure/ sizes

LIBECCIO

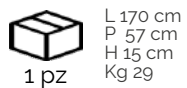

L 170 cm
P 57 cm
H 15 cm
Kg 29

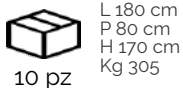

L 180 cm
P 80 cm
H 170 cm
Kg 305

MAESTRALE

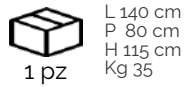

L 140 cm
P 80 cm
H 115 cm
Kg 35

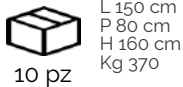

L 150 cm
P 80 cm
H 160 cm
Kg 370

LEVANTE

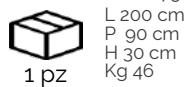

L 200 cm
P 90 cm
H 30 cm
Kg 46



L cm
P cm
H cm
Kg

GRADISCA

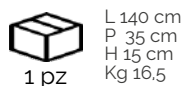
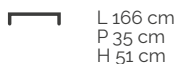

L 140 cm
P 35 cm
H 15 cm
Kg 16,5

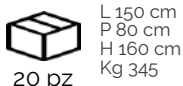

L 150 cm
P 80 cm
H 160 cm
Kg 345

FORNITI SMONTATI
SUPPLIED DISASSEMBLED
FOURNI DÉMONTÉ
SE SUMINISTRA DESMONTADO

p. 128

Finiture in alluminio
Aluminium finishes
Finitions en aluminium
Acabados de aluminio

p. 127

Finiture in legno
Wood finishes
Finitions du bois
Acabados de madera

LIBECCIO - MAESTRALE - LEVANTE

it / Telaio in alluminio verniciato e piano a doghe in legno di frassino.
Ferramenta inox AISI 316.

en / Table with structure in powder coated aluminum frame and ash wood slatted top.
Hardware Inox AISI 316.

fr / Structure en aluminium peint avec des poudre époxy et plateau en lattes en bois frêne.
Quincaillerie en acier inoxydable AISI 316.

es / Estructura de aluminio pintado y tablero de listones de madera de fresno.
Herrajes de acero inoxidable AISI 316.

LIBECCIO TAVOLO/TABLE/TABLE/MESA



MAESTRALE TAVOLO/TABLE/TABLE/MESA



GRADISCA PANCA/BENCH/BANC/BANCO



LEVANTE TAVOLO/TABLE/TABLE/MESA





 misura/ sizes

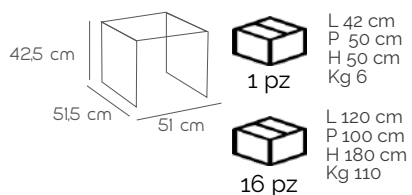
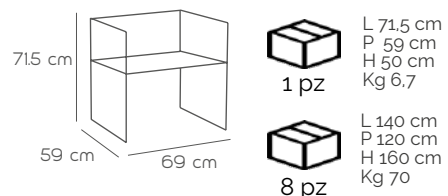
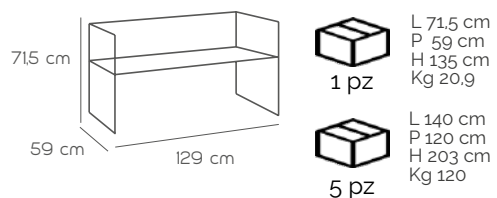

ESAEDRO ALLUMINIO/ALUMINIUM/ALUMINIUM/ALUMINIO

- it / Telaio in alluminio verniciato o anodizzato. Seduta e schienale in tessuto pvc. Tavolino basso con struttura e piano a doghe, in alluminio verniciato o anodizzato. Ferramenta inox AISI 316.
- en / Armchair and Sofa with structure in powder coated or anodized aluminium frame, seat and back with pvc canvas. Low Table with structure and slatted top in powder coated or anodized aluminium frame. Hardware Inox AISI 316.
- fr / Structure en aluminium anodisé ou peint avec des poudres époxy. Assise et dossier en toile pvc. Table basse avec structure et plateau à lattes en aluminium anodisé ou peint avec des poudres époxy. quincaillerie en acier inoxydable AISI 316.
- es / Marco de aluminio pintado o anodizado. Asiento y respaldo de tela de pvc. Mesa baja con estructura y tablero de lamas, de aluminio pintado o anodizado. Herrajes de acero inoxidable AISI 316.



Si consiglia di sostituire le fascette tendi telo ogni anno.
It is recommended to replace the straps that stretch the canvas once per year.
Il est recommandé de remplacer les bandes de tension du toile chaque année.
Se recomienda sustituir las tiras de tensado de la tela cada año.

p. 128
Finiture in alluminio
Aluminium finishes
Finitions en aluminium
Acabados de aluminio

p. 135-136-138
Tessuti COR e RAM
COR and RAM canvases
Toiles COR et RAM
Tejidos COR y RAM



 misure/ sizes

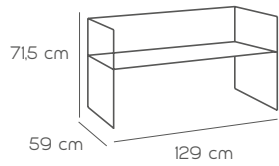

L 71.5 cm
P 59 cm
H 135 cm
Kg 22



L 140 cm
P 80 cm
H 185 cm
Kg 100

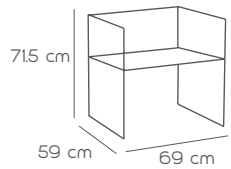

L 71.5 cm
P 59 cm
H 70 cm
Kg 11.6



L 140 cm
P 120 cm
H 160 cm
Kg 108

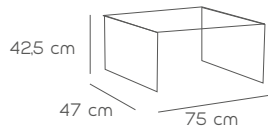

L 42.5 cm
P 47 cm
H 75 cm
Kg 7.5



L 140 cm
P 80 cm
H 185 cm
Kg 100



ESAEDRO LEGNO/WOOD/BOIS/MADERA

p. 128

Finiture in alluminio
Aluminium finishes
Finitions en aluminium
Acabados de aluminio

p. 127

Finiture in legno
Wood finishes
Finitions du bois
Acabados de madera

p. 139

Tessuti MILANO per cuscino
MILANO canvases for cushion
Toiles MILANO pour coussin
Tejidos MILANO para cojin

it / Telaio in alluminio verniciato o anodizzato, seduta e piano tavolo a doghe in legno di frassino. Ferramenta inox AISI 316.

Painted or anodized aluminum frame, seat and top table in wood.

en / Armchair, Sofa, and Low Table, with structure in powder coated or anodized aluminum and ash wood slatted top and seat. Hardware Inox AISI 316.

fr / Structure en aluminium anodisé ou peint avec des poudres époxy. Assise et dossier à lattes en bois de frêne. Quincaillerie en acier inoxydable AISI 316.

es / Marco de aluminio pintado o anodizado, asiento y tablero de madera de fresno. Herrajes de acero inoxidable AISI 316.

OPZIONI / OPTIONS OPTIONNEL/ OPCIONES:

- Cuscino filtrante h 5 cm
- Filtering Cushions h 5cm
- Coussin filtrant h 5 cm
- Cojin filtrante de 5 cm de altura





Cuscino filtrante
Filtering cushion
Coussin filtrant
Cojin filtrante



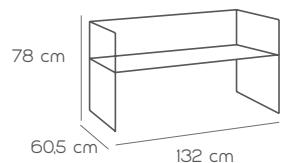

 misure/ sizes

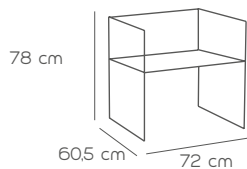

 L 132 cm
P 60.5 cm
H 77 cm
Kg 26.1
1 pz

 L 140 cm
P 120 cm
H 170 cm
Kg 120
4 pz



 L 72.5 cm
P 60 cm
H 77 cm
Kg 20.2
1 pz

 L 140 cm
P 120 cm
H 170 cm
Kg 175
8 pz

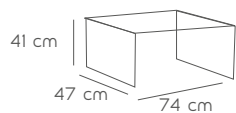

 L 42.5 cm
P 47 cm
H 75 cm
Kg 11
1 pz

 L 140 cm
P 80 cm
H 185 cm
Kg 150
12 pz

**OPZIONI / OPTIONS
OPTIONNEL/ OPCIONES:**

- Legno bicolore
- Cuscino filtrante h 5 cm
- Two-Tone Wood
- Filtering Cushions h 5cm
- Bois bicolore
- Coussin filtrant h 5 cm
- Madera bicolor
- Cojín filtrante de 5 cm de altura



Cuscino filtrante
Filtering cushion
Coussin filtrant
Cojín filtrante



SORRENTO

- it / Struttura realizzata interamente in legno di frassino. Possibilità di scelta della finitura bicolore: fianchi 1 colore; seduta e schienale 1 altro colore. Ferramenta inox AISI 316.
- en / Structure made entirely of ash wood. Possibility of choosing the two-tone finish: sides in 1 color; seat and back 1 other color. Hardware Inox AISI 316.
- fr / Structure entièrement en bois de frêne. Possibilité de choisir la finition bicolore : côtés en 1 couleur ; assise et dossier 1 autre couleur. Quincaillerie en acier inoxydable AISI 316.
- es / Estructura realizada íntegramente en madera de fresno. Opción de acabado bicolor: laterales de un color; asiento y respaldo de otro color. Herrajes de acero inoxidable AISI 316.

p. 127
Finiture in legno
Wood finishes
Finitions du bois
Acabados de madera

p. 139
Tessuti MILANO per cuscino
MILANO canvases for cushion
Toiles MILANO pour coussin
Tejidos MILANO para cojín





Finiture
Finishes
Finitions
Acabados

FINITURE LEGNO / WOOD FINISHES

FINITIONS BOIS / ACABADOS MADERA



it / I nostri lettini, sdraio, sedute e tavoli sono realizzati con **legno di frassino della migliore qualità**, proveniente da foreste austriache e **certificato PEFC** www.pefc.it e **FSC** it.fsc.org/it-it, selezionato ed accuratamente lavorato in spessori tali da **garantire al prodotto la massima resistenza**.

Adatto per l'esterno perchè trattato con impregnazione del legno a più mani con speciali vernici in vasche di colore e con incollaggio delle parti in legno tramite speciale colla marina.

Ferramenta **inox AISI 316**.

Essendo legno, si raccomanda una manutenzione con prodotti specifici per tale materiale.

en / Our sunbeds, deckchairs, seats and tables are made with **the best quality ash wood**, coming from austrian forests and **certified PEFC** www.pefc.it, and **FSC** it.fsc.org, selected and carefully worked in thicknesses such as **to ensure the maximum resistance**.

Suitable for outdoors because it is treated with impregnation of the wood in several hands with special paints in color vats, and with gluing of the wooden parts using special marine glue.

AISI 316 stainless steel hardware.

Since it is wood, the maintenance with specific products for this material is recommended.

fr / Nos transats, chiliennes, sièges et tables sont fabriqués avec du **bois de frêne de la meilleure qualité**, provenant de forêts autrichiennes et **certifié PEFC** www.pefc.it et **FSC** it.fsc.org, sélectionnés et soigneusement travaillés dans des épaisseurs telles qu'ils **garantissent la résistance maximale**.

Idéal pour l'extérieur car il est traité avec une imprégnation du bois en plusieurs couches avec des peintures spéciales dans des baignoires avec couleur, et avec collage des parties en bois à l'aide d'une colle marine spéciale.

Quincaillerie en **acier inoxydable AISI 316**.

Puisqu'il s'agit de bois, l'entretien avec des produits spécifiques pour ce matériau est recommandé.

es / Nuestras tumbonas, tumbonas, asientos y mesas están hechas de **madera de fresno de la mejor calidad**, procedente de bosques austriacos y **certificado PEFC** www.pefc.it y **FSC** it.fsc.org, seleccionado y trabajado cuidadosamente en espesores que **garantizan al producto la máxima resistencia**.

Adecuada para exteriores porque ha sido tratada impregnando la madera en varias capas con pinturas especiales en tanques de color y pegando las partes de madera con cola marina especial.

Herrajes de **acero inoxidable AISI 316**.

Al ser de madera, se recomienda el mantenimiento con productos específicos para dicho material.



BIANCO PIENO
FULL WHITE
BLANC PLEIN
BLANCO SÓLIDO



SBIANCATO
BLEACHED
BLANCHI
BLANQUEADO



NATURALE
NATURAL
NATUREL
NATURAL



NOCE
WALNUT
NOYER
NOGAL



MOGANO CHIARO
LIGHT MAHOGANY
ACAJOU CLAIR
CAOBA CLARA



MOGANO SCURO
DARK MAHOGANY
ACAJOU FONCÉ
CAOBA OSCURA



TORTORA
DOVE GREY
TOURTERELLE
GRIS PALOMA



WENGÉ
WENGÉ
WENGÉ
WENGÉ



NERO
BLACK
NOIR
NEGRO

FINITURE ALLUMINIO / ALUMINIUM FINISHES

FINITIONS ALUMINIUM / ACABADOS ALUMINIO



it / I nostri lettini, sdraio, sedute e tavoli sono costruiti con **alluminio di prima scelta**. Grazie allo speciale trattamento di anodizzazione a cui sono sottoposti, è garantita una **perfetta inalterabilità** anche nelle peggiori condizioni d'uso. Tutta la ferramenta è in **acciaio inox AISI 316**. L'alluminio dei nostri articoli può essere richiesto nelle seguenti colorazioni:

en / Our sunbeds, deckchairs, seats and tables are manufactured with **top quality aluminium**. Thanks to the special anodizing treatment to which they are subjected, the **perfect inalterability is guaranteed** even in the worst conditions of use. All the hardware is in **AISI 316 stainless steel**. The aluminum of our items can be requested in the following colours:

fr / Nos transats, chiliennes, sièges, et tables sont fabriqués en **aluminium de la plus haute qualité**. Le traitement spécial d'anodisation auquel ils sont soumis **garantit une parfaite inaltérabilité** même dans les pires conditions d'utilisation. Toute la quincaillerie est en **acier inoxydable AISI 316**. L'aluminium de nos articles peut être demandé dans les couleurs suivantes:

es / Nuestras tumbonas y sillas son de **aluminio de alta calidad**. Gracias al tratamiento especial de anodización al que se someten, se **garantiza una perfecta inalterabilidad** incluso en las peores condiciones de uso. Todos los herrajes son de **acero inoxidable AISI 316**. El aluminio de nuestros artículos puede pedirse en los siguientes colores:

ANODIZZATI / ANODIZED ANODISÉS / ANODIZADOS



Argento
Silver
Argent
Plateado

Disponibile per / Available for Disponibile pour / Disponible para:

- Santorini
- Base/Base 3P
- Young
- T3/T3 new
- Superior
- T4
- Kommodo
- Riccione
- Rio
- Vip
- 5 Stelle
- Baby
- Marinella
- Sdraio
- Aurora
- Regista
- Sgabello Regista
- Elegant
- Elegant H
- Piano alluminio
- Tavoli pieghevoli
- Tavoli bassi
- Esaedro

ANODIZZATI / ANODIZED ANODISÉS / ANODIZADOS



Bronzo-Oro
Bronze-Gold
Bronze-Or
Bronce-Oro



Champagne

Disponibili per / Available for Disponibile pour / Disponible para:

- Base/Base 3P
- T3 /T3 new
- Young
- Superior
- T4
- Kommodo
- Riccione
- Rio
- Vip
- 5 Stelle
- Baby
- Marinella
- Sdraio
- Aurora
- Regista
- Sgabello Regista

SUBLIMATI / SUBLIMATED SUBLIMÉS / SUBLIMADOS



Effetto legno
Wood effect
Effet bois
Efecto madera

Disponibile per / Available for Disponibile pour / Disponible para:

- T3
- RIO

it / Tutti i colori RAL sono disponibili per quantitativi. **La produzione di serie dell'alluminio è anodizzato color argento**. Per coloriture diverse, è necessaria una prenotazione con largo anticipo sui tempi di consegna. Tutti i nostri lettini sono dotati del sistema SICUR-BLOCK sostitutivo delle staffe e collaudato da decenni.

en / All RAL colours are available for quantities. **The series production of aluminum is in silver anodized**. For any other color, the order is required well in advance compared to the standard delivery time. All our sunbeds are equipped with the SICUR-BLOCK system which replaces the brackets and has been tested for decades.

fr / Toutes les couleurs RAL sont disponibles pour les quantités. **La finition standard de l'aluminium est l'anodisé argent**. Pour finitions différentes, une réservation est nécessaire bien avant les délais de livraison standard. Tous nos transats sont équipés du système SICUR-BLOCK qui remplace les supports, et a été testé pendant des décennies.

es / Todos los colores RAL están disponibles para cantidades. **La producción de serie del aluminio es anodizado color plateado**. Para colores diferentes, hay que reservar con mucha antelación. Todas nuestras tumbonas están equipadas con el sistema de sustitución de soportes SICURBLOCK, que ha sido probado durante décadas.

VERNICIATI - POWDER COATED - PEINT AVEC DES POUDRE ÉPOXY - PINTADOS



RAL 9016
Bianco lucido
Gloss white
Blanc brillant
Blanco brillante



RAL 7006
Talpa opaco
Matt taupe
Taupe matt
Taupe opaco



RAL 9006
Grigio metallizzato opaco
Matt metal grey
Gris métallisé mat
Gris metalizado mate



RAL 7016
Grigio antracite opaco
Matt anthracite grey
Gris anthracite mat
Gris antracita mate



RAL 8017
Marrone opaco
Matt Brown
Marron mat
Marrón mate



RAL 9005
Nero opaco
Matt black
Noir mat
Negro mate

Disponibili per tutti gli articoli. / Available for all items. / Disponible pour tous les articles. / Disponible para todos los artículos.

ESEMPI DI FINITURE ALLUMINIO / EXAMPLES OF ALUMINIUM FINISHES

EXEMPLES DE FINITIONS ALUMINIUM / EJEMPLOS DE ACABADOS ALUMINIO



Anodizzato Champagne
Champagne anodized
Anodisés Champagne
Anodizados Campagne



Verniciato Antracite opaco
Matt anthracite powder coated
Anthracite matt peint avec des poudre époxy
Antracita mate pintados



Verniciato Talpa opaco
Matt taupe powder coated
Taupe mat peint avec des poudre époxy
Taupe mate pintados



Sublimato effetto legno: T3-RIO
Wood effect sublimated: T3-RIO
Effet bois sublimés: T3-RIO
Efecto madera sublimados: T3-RIO



Anodizzato Bronzo-Oro
Bronze-Gold Anodized
Anodisés Bronze-Or
Anodizados Bronce-Oro



Verniciato Nero opaco
Matt black powder coated
Noir mat peint avec des poudre époxy
Negro mate pintados



Verniciato Bianco
White powder coated
Blanc peint avec des poudre époxy
Blanco pintados



it / **PVC CON CARATTERISTICHE
IGIENIZZANTI E SANIFICANTI**

--> Sistema igienizzante e sanificante

Il nostro tessuto pvc, prodotto da **Ramfil Srl**, azienda del gruppo Ramberti, ha caratteristiche igienizzanti e sanificanti grazie all'inserimento di un trattamento antimicrobico che consente una azione fungistatica e batteriostatica evitando il rischio di infezioni, efficace contro un largo spettro di germi, lieviti e muffe. Nello specifico questo additivo agisce sulla parete della cellula del microorganismo, privandola della capacità di nutrirsi e quindi di crescere e proliferare.

**--> Sicurezza di igiene e pulito che dura
nel tempo**

Il trattamento è integrato nel processo di fabbricazione del filo e diventa parte intrinseca del materiale aumentandone la resistenza all'attacco dei microrganismi. Non viene rilasciato all'esterno.

Vantaggi del nostro tessuto PVC:

- » Protezione dal danneggiamento bloccando l'adesione di funghi, alghe e muffe;
- » Ottima solidità all'azione dilavante dell'acqua;
- » Buona resistenza alla putrefazione;
- » Impedisce la formazione di macchie colorate di origine microbica (pink stain)
- » Compatibilità con l'ambiente.

Il nostro tessuto pvc è **realizzato con materie prime pienamente conformi ai Regolamenti nazionali ed internazionali vigenti**. In particolare il prodotto soddisfa quanto previsto dal Regolamento REACH n. 1907/2006.

en / **PVC WITH HYGIENIZING AND SANI-
TIZING CHARACTERISTICS**

--> Hygienizing and sanitizing system

Our pvc canvas, produced by **Ramfil Srl**, one of the Ramberti Group companies, have hygienizing and sanitizing characteristics thanks to the inclusion of an antimicrobial treatment, which allows a fungistatic and bacteriostatic action avoiding the risk of infections, as well as effective against a wide spectrum of germs, yeasts, and molds. Specifically, this additive acts on the cell wall of the microorganism, depriving it of the ability to feed itself and therefore to grow and proliferate.

**--> Safety of hygiene and clean which lasts
over time**

The treatment is integrated into the manufacturing process of the wire, and becomes an intrinsic part of the material, increasing its resistance to attack by microorganisms, and is not released to the outside.

--> Advantages of our PVC fabrics:

- » Protection from damage by blocking the adhesion of fungi, algae, and molds
- » Excellent solidity to the washing action of water
- » Good rot resistance
- » Prevents the formation of colored spots of microbial origin (pink stain)
- » Compatibility with the environment

Our pvc fabrics are made **with raw materials that fully comply with the National and International Regulations in force**. In particular, the product meets the requirements of the REACH Regulation n. 1907/2006.



fr/ PVC AVEC CARACTÉRISTIQUES ASSAINISSANTES ET DÉSINFECTANTS

es/ PVC CON CARACTERÍSTICAS HIGIENIZANTES Y DESINFECTANTES

--> Système d'assainissement et de désinfection

Notre toile pvc, produit par **Ramfil Srl**, une société du groupe Ramberti, possède des caractéristiques assainissantes et désinfectantes grâce à l'inclusion d'un traitement antimicrobien qui permet une action fongistatique et bactériostatique évitant le risque d'infections, efficace contre un large spectre de germes, levures et moisissures.

En particulier, cet additif agit sur la paroi cellulaire du micro-organisme, le privant de la capacité de se nourrir et donc de se développer et proliférer.

--> Sécurité d'hygiène et propreté qui durent dans le temps

Le traitement est intégré au processus de fabrication du fil et devient une partie intrinsèque du matériau, augmentant sa résistance aux attaques des micro-organismes. Il n'est pas relâché à l'extérieur.

Avantages de notre tissu PVC:

- » Protection contre les dommages en bloquant l'adhésion des champignons (mycose), des algues, et des moisissures
- » Excellente solidité à l'action lavante de l'eau ;
- » Bonne résistance à la pourriture;
- » Empêche la formation de taches colorées d'ordre microbien (tache rose)
- » Compatibilité avec l'environnement.

Notre tissu pvc est **fabricé à partir de matières premières entièrement conformes aux réglementations nationales et internationales en vigueur**. En particulier, le produit est conforme aux dispositions du règlement REACH n. 1907/2006.

--> Sistema de higienización y desinfección

Nuestro tejido de pvc, producido por Ramfil Srl, empresa del Grupo Ramberti, tiene características higienizantes y desinfectantes gracias a un tratamiento antimicrobiano que permite una acción fungistática y bacteriostática evitando el riesgo de infección, eficaz contra un amplio espectro de gérmenes, levaduras y mohos.

En concreto, este aditivo actúa sobre la pared celular del microorganismo, privándole de su capacidad de alimentarse y, por tanto, de crecer y proliferar.

--> Seguridad de higiene y limpieza que dura a lo largo del tiempo

El tratamiento se integra en el proceso de fabricación del hilo y se convierte en parte intrínseca del material, aumentando su resistencia al ataque de los microorganismos. No se libera al exterior.

Ventajas de nuestro tejido de PVC:

- » Protección contra daños al bloquear la adhesión de hongos, algas y moho;
- » Excelente resistencia a la acción de lavado del agua;
- » Buena resistencia a la putrefacción;
- » Evita la formación de manchas microbianas de color (mancha rosa);
- » Compatibilidad con el medio ambiente.

Nuestro tejido de pvc está **fabricado con materias primas que cumplen plenamente la normativa nacional e internacional vigente**. En particular, el producto cumple con el Reglamento REACH n.º 1907/2006.





bianco



beige



giallo 1195

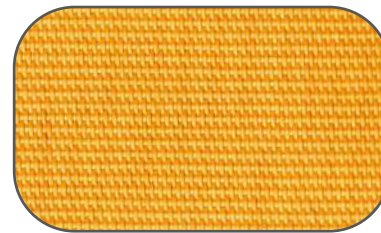

giallo 824

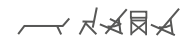

arancio

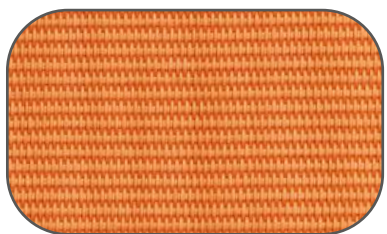
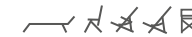

salmone

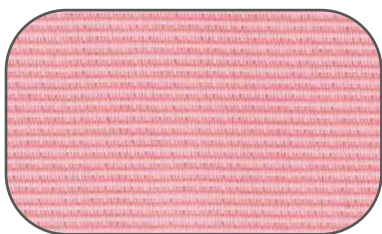

rosa

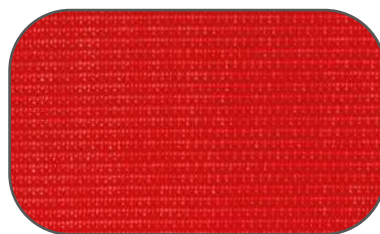

rosso

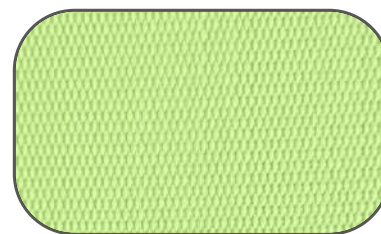

verde pistacchio

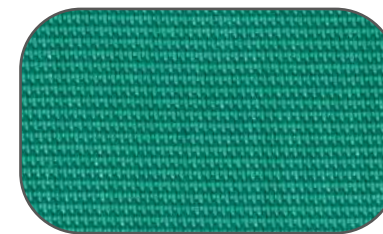

verde



turchese



blu



blu cobalto



talpa

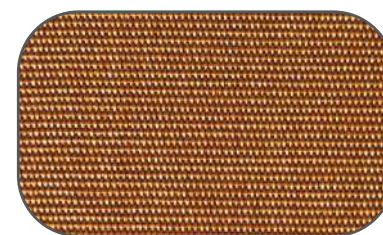

bronzo

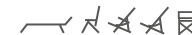

testa di moro

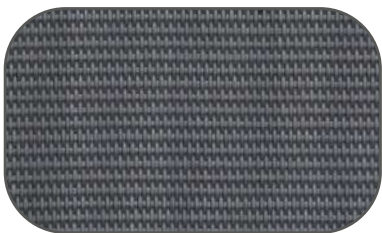

grigio

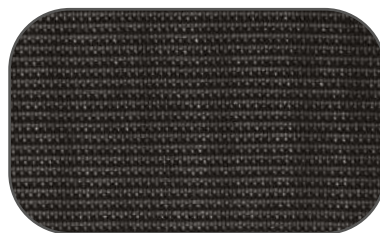

nero



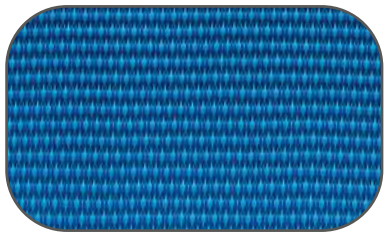

Jeans



C333

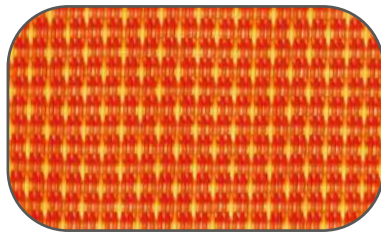

856



melange beige

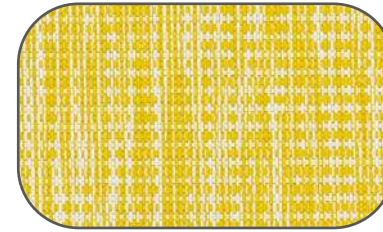

melange giallo bianco

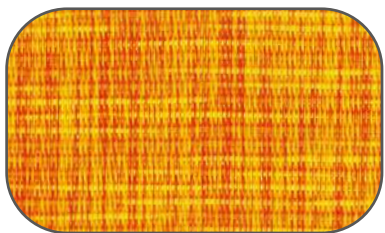

sunshine



melange bordeaux

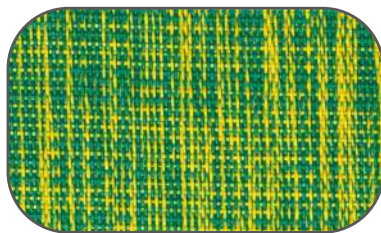
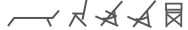

melange verde giallo



melange verde verde

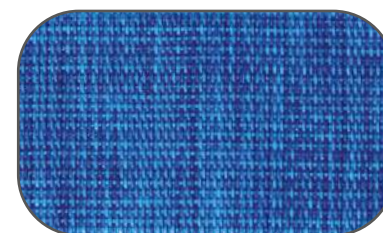

melange blu

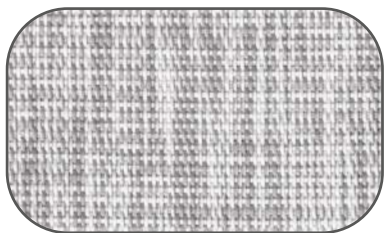

melange grigio mercury

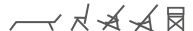

melange grigio granito



collezione collection **ROMAGNA**



840



841



842



843



846



114



803



804



800/F



801/F



805/F



119



848



845



805



806



860



861



862



863



865



866



867



808



810



bianco 833



beige 149

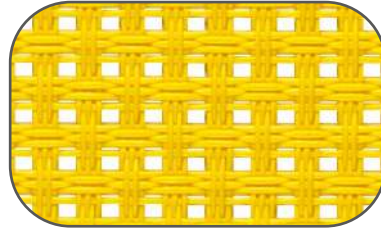

giallo 1195

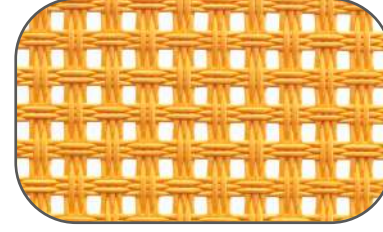

giallo 824

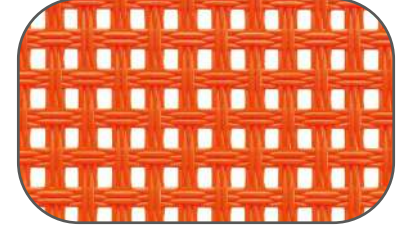

arancio 820

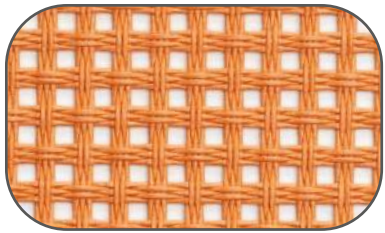

salmone

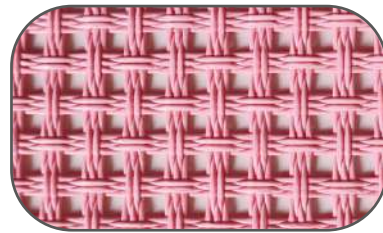

rosa

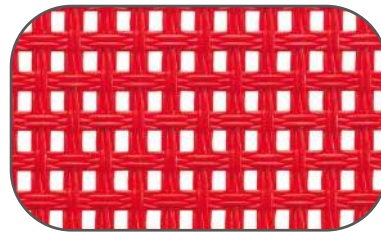

rosso 827

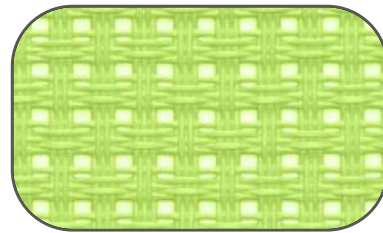

verde pistacchio

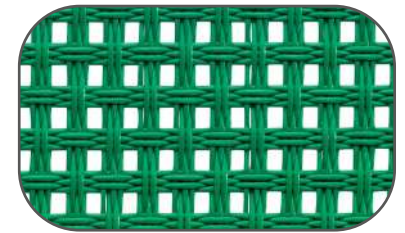

verde 821

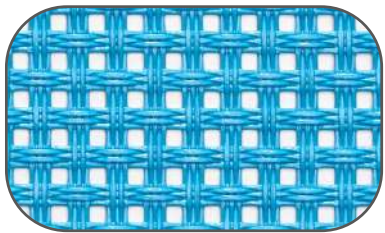

turchese

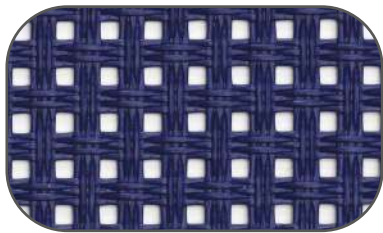

blu cobalto

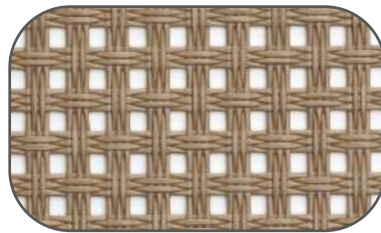

talpa

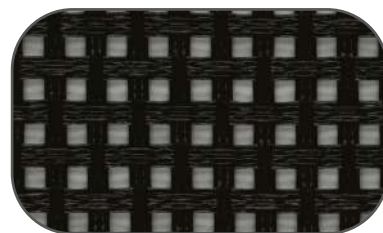

nero

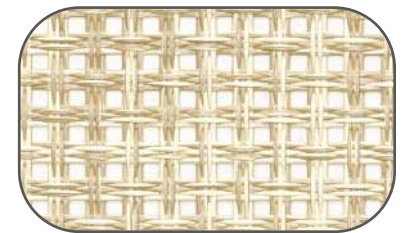

melange beige 0155

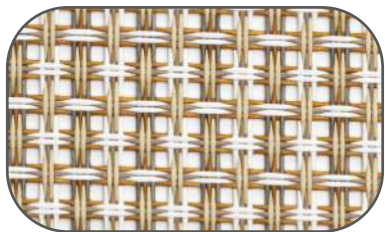

sabbia

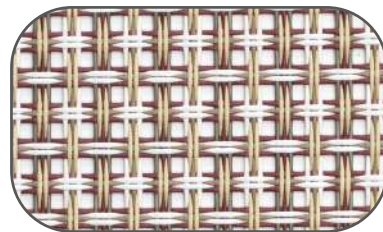

ruggine

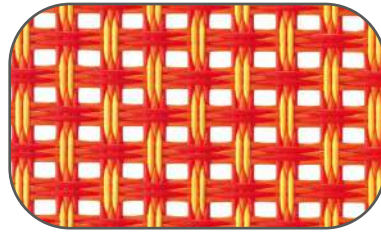

866

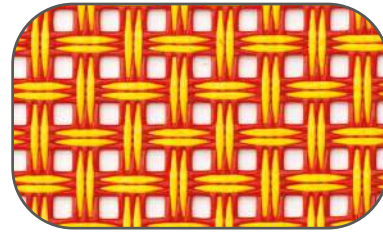

gitano

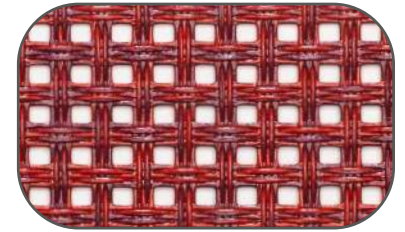

melange bordeaux

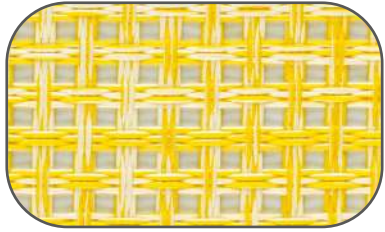

melange giallo bianco

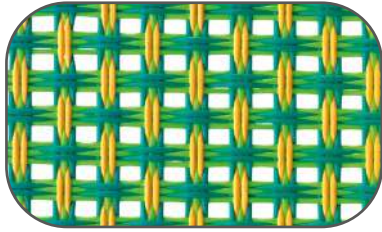

865

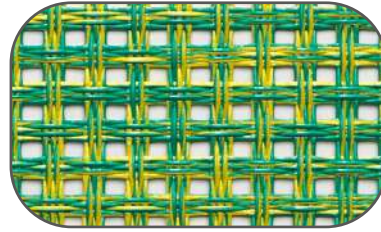

melange verde giallo

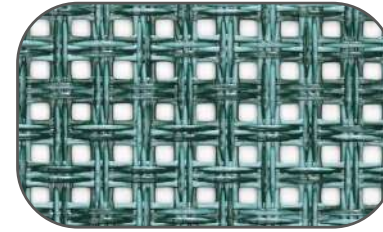

melange verde verde

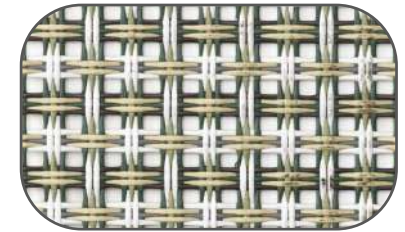

prato

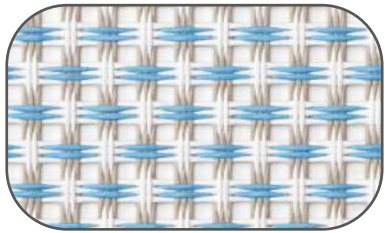

6003

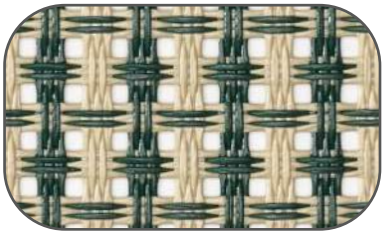

5009

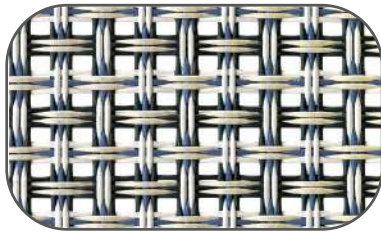

4415

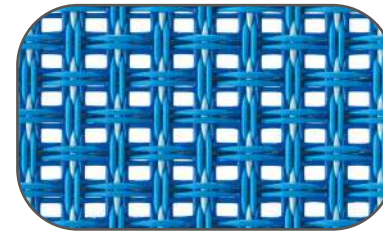

4413

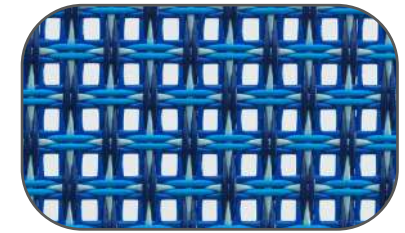

4131

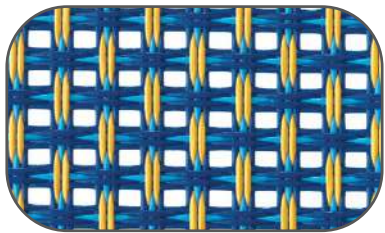

861

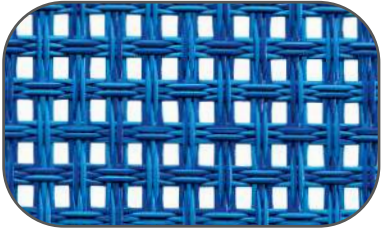

melange blu

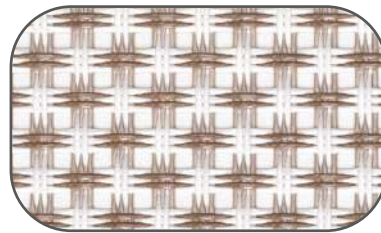

jersey

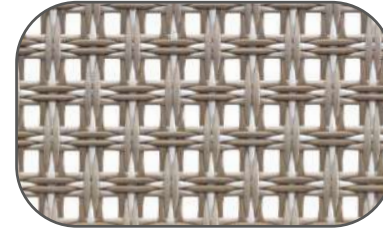

mosquito

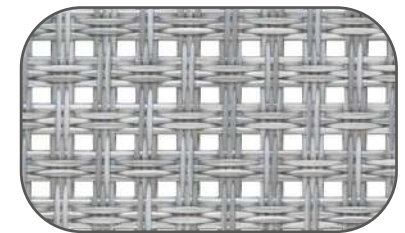

melange grigio mercury

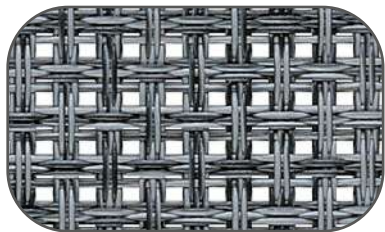

melange grigio granito

it / Per i nostri lettini in abbinamento al tessuto COR consigliamo il tettuccio con tessuto ROMAGNA.
 en / For our sunbeds, in combination with the COR fabric, we suggest the sunshield with ROMAGNA fabric.
 fr / Pour nos transats, en combinaison avec le tissu COR, nous recommandons le pare-soleil avec le tissu ROMAGNA.
 es / Para nuestras tumbonas en combinación con el tejido COR recomendamos el dosel con tejido ROMAGNA.

esempi / examples / exemples / ejemplos

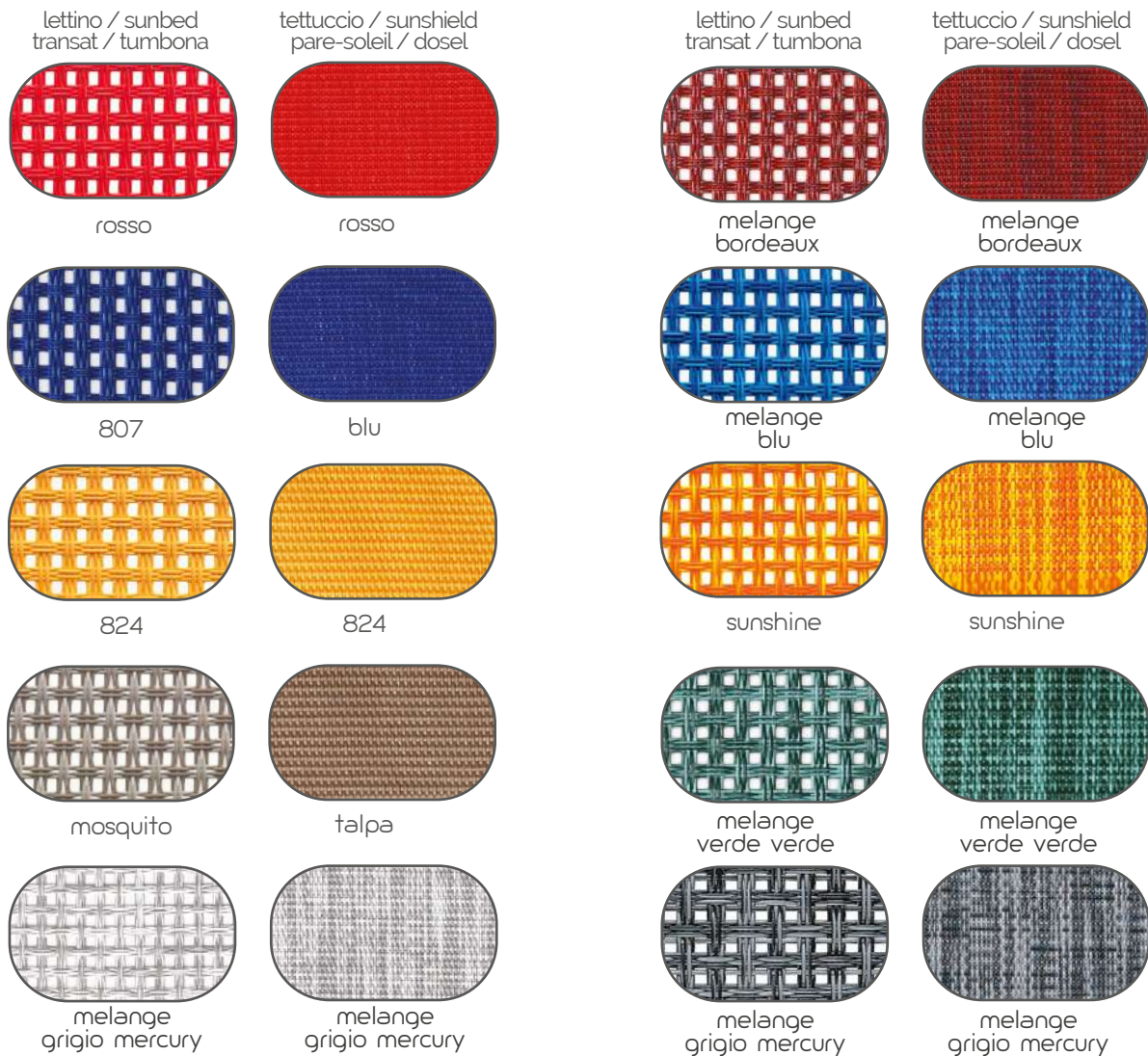

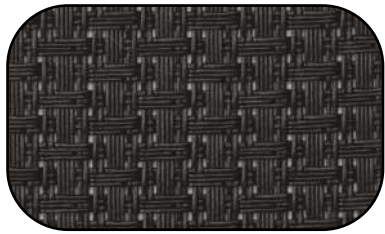

000

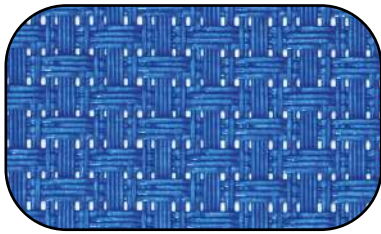

101



102

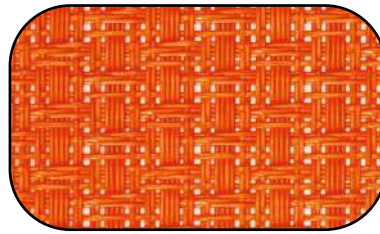

103

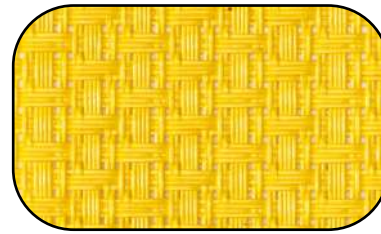

104

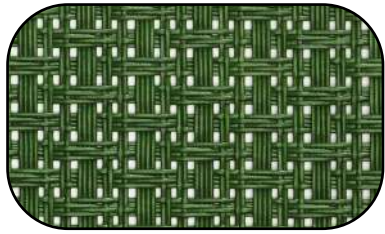

105



106



107

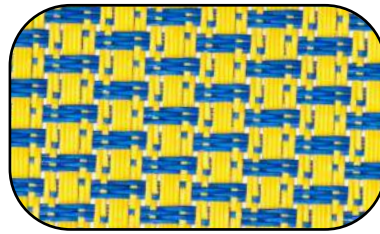

108

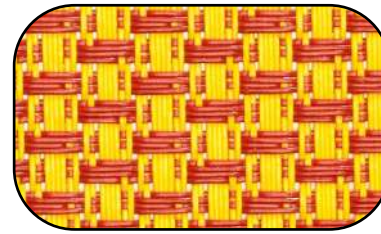

110

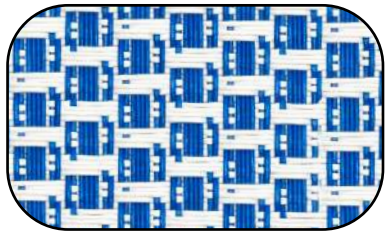

111

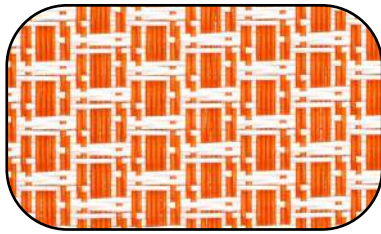

112



113

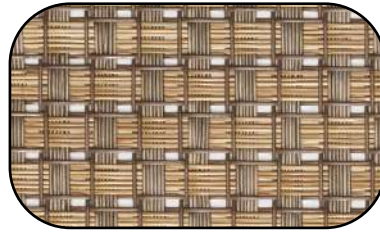

114

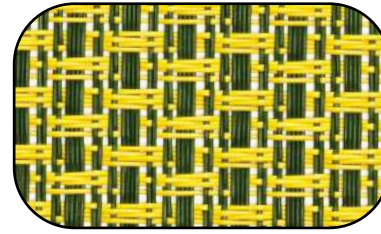

115

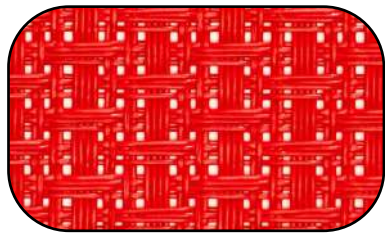

116

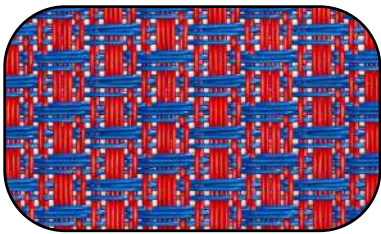

117

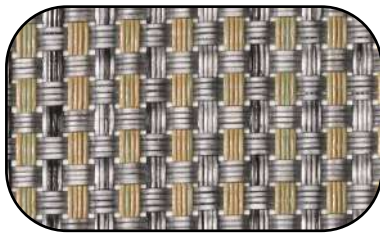

118

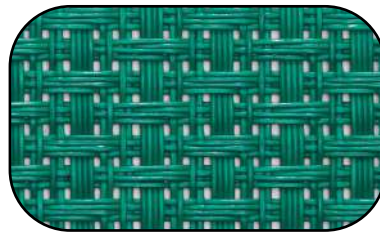

119



120

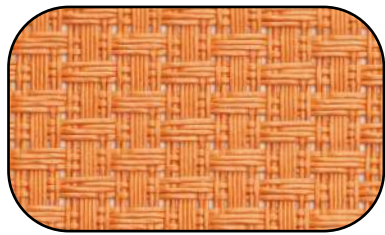

121

138

Le immagini dei campioni colore sono indicative e possono subire variazioni cromatiche.
The images of the color samples are indicative and may have chromatic variations.

Les images des échantillons de couleurs sont indicatives et peuvent subir des variations chromatiques.
Las imágenes de muestra de color son indicativas y pueden estar sujetas a variaciones de color.

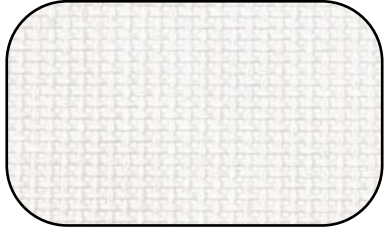

bianco



beige

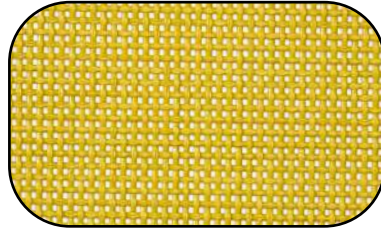

cedro

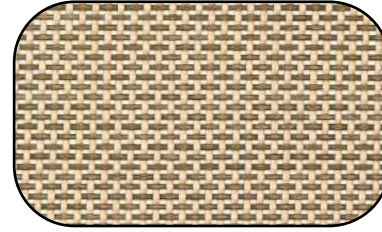

noce



arancio

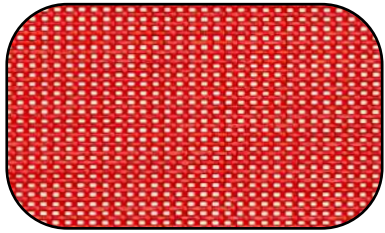

rosso

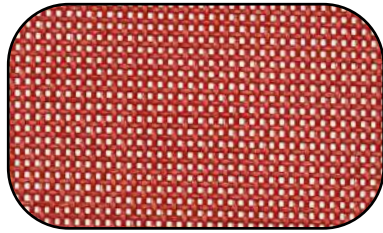

corallo



tortora



talpa

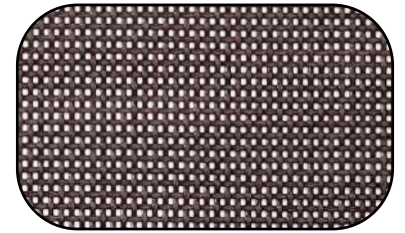

melanzana

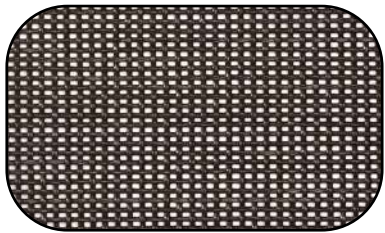

testa di moro

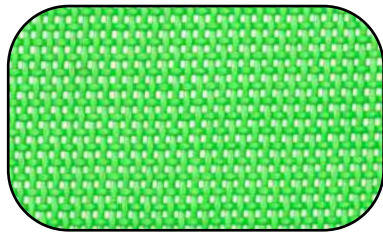

prato

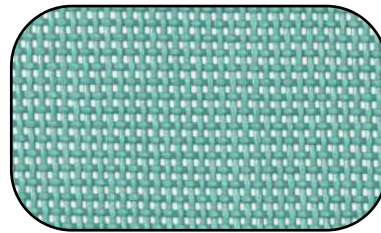

verde acqua

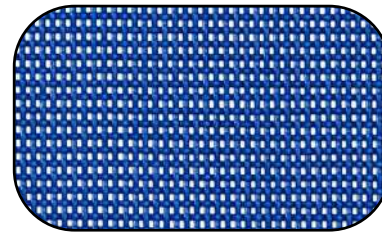

blu

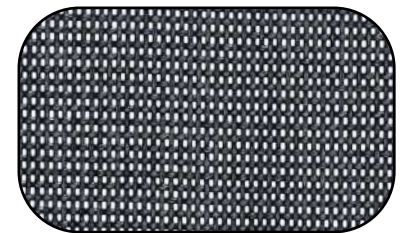

notte

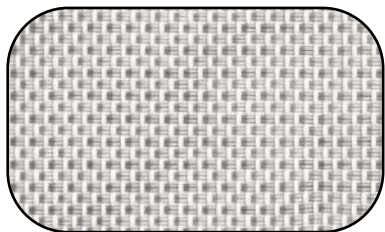

alluminio

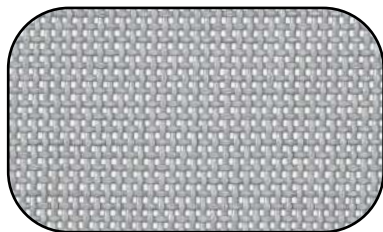

grigio topo

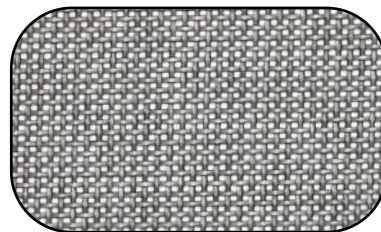

argento

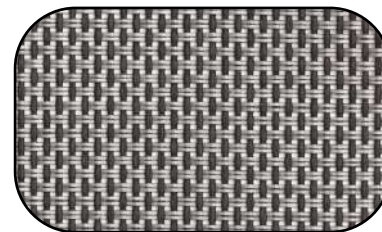

metal

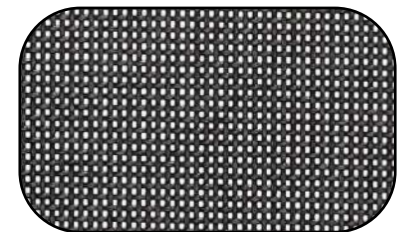

nero

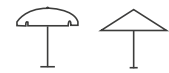

BORDINI / ACRYLIC EDGES



101/G604 BIANCO



407/G221



704/Z645



502



603



102/G687



409



402/G209



601/G599



605/G245



706/G596



408/R035



404/G101



606

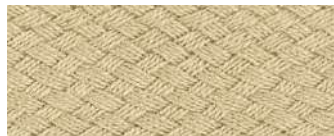

707/G038



302/G180



401/G211



509/G252

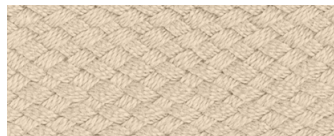

708/G822



355/G142

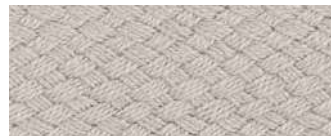

801/Z647



510/Z650

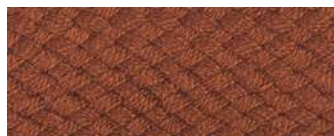

702/G070



201/Z661

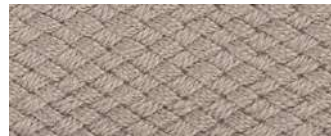

802/G102



575

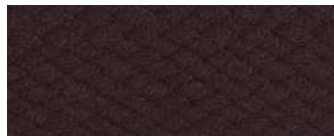

703/G316



301/G050



506

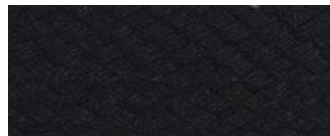

901/G170 NERO

Le immagini dei campioni colore sono indicative e possono subire variazioni cromatiche.
The images of the color samples are indicative and may have chromatic variations.

Les images des échantillons de couleurs sont indicatives et peuvent subir des variations chromatiques.
Las imágenes de muestra de color son indicativas y pueden estar sujetas a variaciones de color.

PERSONALIZZAZIONE / CUSTOMIZATIONS PERSONNALISATION / PERSONALIZACIÓN

- it / Gli ombrelloni, i lettini, le sdraio, le poltroncine, i cuscini e i materassini filtranti, possono essere personalizzati sia con semplice dicitura con vari caratteri di stampa, sia con la riproduzione del logo dell'acquirente che provvederà ad inviarci in formato vettoriale. Di seguito alcuni esempi.
- en / The parasols, sunbeds, deck chairs, armchairs, cushions and mattresses, can be customized either with a simple wording with various print characters, or with the reproduction of the customer's own logo which will be sent to us in vector format. Here below some examples.
- fr / Les parasols, les transats, les fauteuils, les chiliennes, les coussins et matelas filtrants peuvent être personnalisés soit avec une simple inscription avec différents caractères d'impression, soit avec la reproduction du logo du client qui nous sera transmis en format vectoriel. Ci-dessous quelques exemples.
- es / Las sombrillas, las tumbonas, las sillas, los cojines y las colchonetas filtrantes pueden personalizarse con un simple texto en varias fuentes de impresión o con la reproducción del logotipo del comprador, que se nos debe enviar en formato vectorial. He aquí algunos ejemplos.

Stampa termosaldada/Heat sealed/Hermosoudés/Impresión termosellada



Carattere standard
Standard font
Caractère standard
Carácter estándar



Carattere personalizzato
Customized font
Caractère personnalisé
Fuente personalizada

Colori di stampa:
Printing colors:
Couleurs d'impression:
Colores de impresión:



Carattere standard per scritte lunghe
Standard font for long text
Caractère standard pour les longues inscriptions
Tipo de letra estándar para textos largos

Stampa serigrafica / Silkscreen printing / Impression en sérigraphie / Serigrafía



MANUTENZIONE / MAINTENANCE ENTRETIEN / MANTENIMIENTO

it / Nel periodo invernale possiamo curare la **manutenzione** dei prodotti usurati, deteriorati o danneggiati.
Tale servizio viene svolto su tutta la produzione illustrata nel presente catalogo, in quanto produttori diretti di tutto ciò che viene proposto.
Sono disponibili i **ricambi per tutti gli articoli**.
Inviateci le vostre fotografie via email.

en In the winter period, we can take care of the maintenance of worn, deteriorated or damaged products.
This service is carried out on all the production illustrated in this catalog, as we are the producers of all the items which are shown in the same.
Spare parts are available for all items.
Send us your photos by email.

fr / En hiver nous pouvons nous occuper de l'entretien des produits usés, détériorés ou endommagés.
Ce service est réalisé sur toute la production illustrée dans ce catalogue, car nous sommes producteurs directs de tout ce qui est proposé.
Des **pièces de rechange** sont disponibles pour tous les articles.
Envoyez-nous vos photos par email.

es / Durante el invierno, podemos ocuparnos del mantenimiento de los productos desgastados, deteriorados o dañados.
Este servicio se realiza sobre toda la producción ilustrada en este catálogo, ya que somos productores directos de todo lo que se ofrece.
Las **piezas de repuesto** están disponibles para todos los artículos.
Envíanos tus fotos por correo electrónico.



LA TELONERIA

it / Confezioniamo su misura teloni, pareti finestrate e coperture in pvc.

en We tailor-made pvc side walls with windows and covers.

fr / Nous réalisons sur mesure parois latérales avec fenêtres et couvertures en pvc.

es / Fabricamos lonas y cubiertas de pvc a medida.



**RAMBERTI S.r.l**

via del Tiglio 19

47822 Santarcangelo di Romagna (RN) Italy

Tel. +39 0541 621206 - Fax +39 0541 620724

info@ramberti.com - www.ramberti.com

MIGANI INDUSTRIE S.r.l

via Colombarina 28/30

47853 Coriano (RN) Italy

Tel./Fax +39 0541 657213

info@migani.it - www.migani.it

LA TELONERIA

via Santarcangiolese (ex Bowling)

Poggio Toriana (RN) - Italy

Tel. +39 338 2912934

lateloneria@ramberti.com

Ramberti Points:

≡ Via al Piemonte (Polo 90) - 17031 Albenga (SV) - ITALY

≡ Via Domenico Federici n.11 - 04012 Cisterna di Latina (LT) - ITALY

≡ Lagja n.1 Sallbeg - Kavajë - Tirana - ALBANIA